

CONTAINERBRÜCKE

CONTAINER BRIDGE-CRANE
PORTIQUE À CONTENEURS
CONTAINERKRAAN

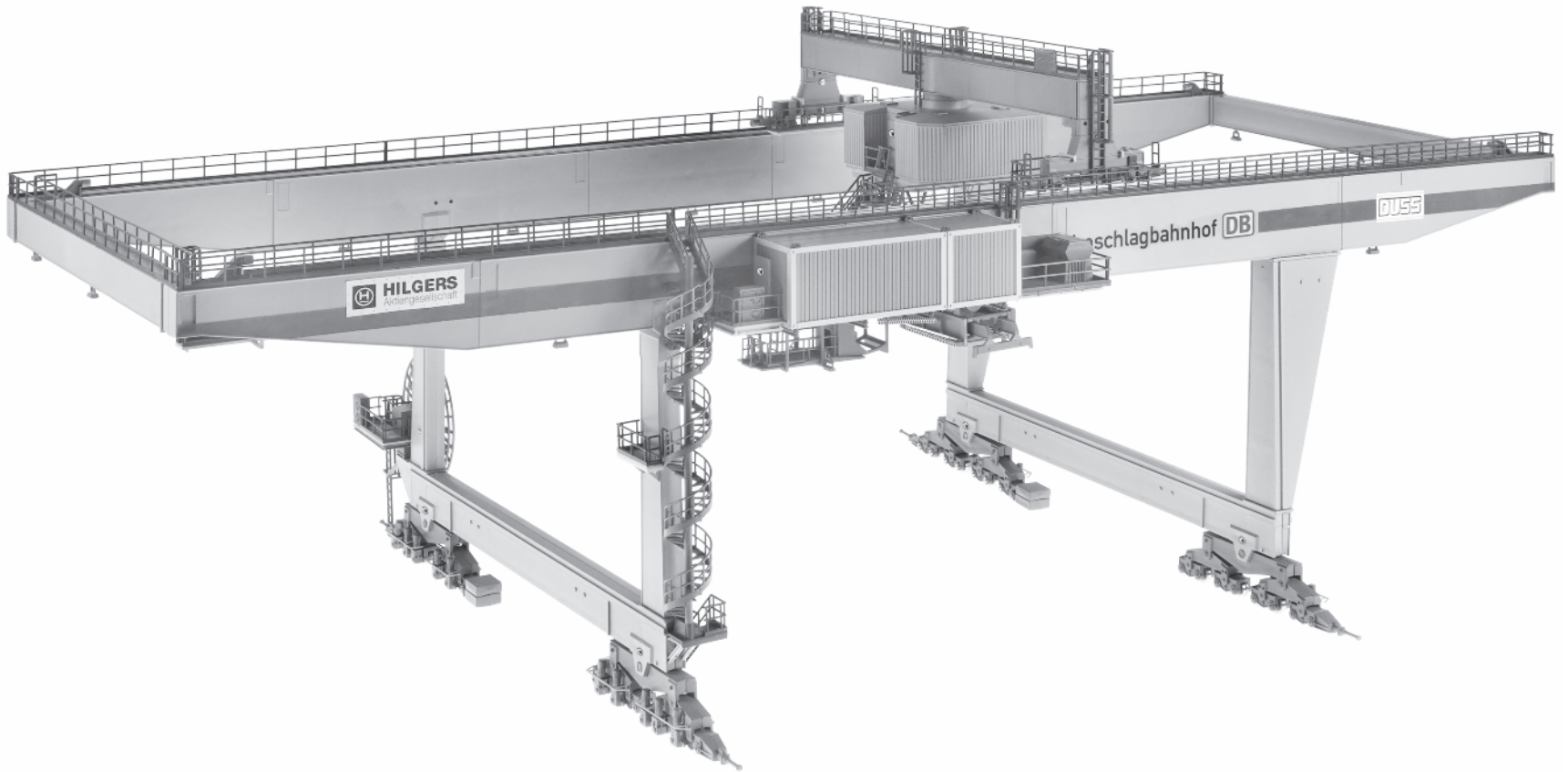

Art. Nr. 120290



Sa. Nr. 120 290 1

D Vor Beginn des Bastelns sollten Sie sich mit den Spritzlingen und der Anleitung vertraut machen. Sollte es einmal vorkommen, dass ein Teil im Bausatz fehlt, kreuzen Sie bitte das fehlende Teil in der Anleitung an und schicken Sie diese bitte an Fa. Gebr. FALLER GmbH, Abt. Kundendienst, kundendienst@faller.de, Kreuzstraße 9, 78148 Gütenbach. Sie erhalten dann umgehend Ersatz. Es kann vorkommen, dass bei einem Bausatz Einzelteile übrig sind.

GB Before beginning with the assembly please familiarize yourself with the parts and read the instructions carefully. In case of missing parts please indicate these on the instructions leaflet with a circle and return the leaflet to Gebr. FALLER GmbH, kundendienst@faller.de, Kreuzstraße 9, D-78148 Gütenbach, Germany. You will receive the replacement by return. It may happen in a kit that some parts are not required.

F Avant de commencer le montage de votre maquette bien lire la notice et repérer les grappes. Si une pièce manque dans une boîte, cochez la pièce correspondante sur la notice et renvoyez-la-nous à Gebr. FALLER GmbH, kundendienst@faller.de, Kreuzstraße 9, D-78148 Gütenbach (R.F.A.). Nous vous ferons parvenir la pièce par retour. Dans certains kits, il est possible que certaines pièces ne soient pas utilisées.

NL Vóór het bouwen zou men de gietstukken en de handleiding moeten bestuderen. Indien onverhoopt een onderdeel aan het bouwpakket ontbreekt, gelieve men het ontbrekende deel in de handleiding aan te kruisen en deze te zenden aan Gebr. FALLER GmbH, kundendienst@faller.de, Kreuzstraße 9, D-78148 Gütenbach. U ontvangt dan omgaand en gratis het ontbrekende onderdeel. Het kan voorkomen dat u bij bepaalde bouwdozen onderdelen overhoudt.



170492
FALLER-EXPERT
Flüssigkleber in Plastikflasche mit Spezialkanüle für feinste Klebstoffdosierung.

FALLER-EXPERT
Liquid cement in plastic bottle with canule for very fine dosage.

FALLER-EXPERT
Colle liquide en bouteille plastique avec bec verseur pour un dosage précis.

FALLER-EXPERT
Vloeibare lijm in plastic-fles met doseerbuisje om nauwkeurig te lijmen.



170688
Spezial-Seitenschneider
zum gratfreien Abtrennen von feinsten Spritzteilen. Spitze 48° abgewinkelt. Nur für Polystyrol geeignet.

Special side cutter
for cutting off ultra-fine moulded parts without burrs. Tip angle 48°. Only suitable for polystyrene.

Pince coupante spéciale
pour couper sans bavure les pièces miniatures moulées par injection. Pointe coudée à 48°. Uniquement appropriée pour le polystyrène.

Speciale zijknijptang
voor het braamloos afknippen van de fijnste gietstukdelen. Hoek snijvlakken 48°. Alleen geschikt voor polystyrol.

Für die Montage benötigen Sie Plastik-Klebstoff und Expert Lasercut-Kleber.

Wir empfehlen:

FALLER-Klebstoff EXPERT (Art. Nr. 170492)
FALLER-Klebstoff EXPERT-Lasercut (Art. Nr. 170494)
FALLER EXPERT RAPID (Art. Nr. 170500)
FALLER-Spezial-Seitenschneider (Art. Nr. 170688)
FALLER-Bastelmesser (Art. Nr. 170687)

For mounting you need plastic cement and Lasercut cement.

Our recommendation:

FALLER cement EXPERT (Art. No. 170492)
FALLER cement EXPERT-Lasercut (Art. No. 170494)
FALLER EXPERT RAPID (Art. No. 170500)
FALLER special side cutter (Art. No. 170688)
FALLER modeller's knife (Art. No. 170687)

Pour le montage, utiliser de la colle plastique et de la colle Lasercut.

Nous vous recommandons les produits suivants:

Colle FALLER EXPERT (Art. Nr. 170492)
Colle FALLER EXPERT-Lasercut (Art. Nr. 170494)
FALLER EXPERT RAPID (Art. Nr. 170500)
Pince coupante diagonale spéciale FALLER (Art. Nr. 170688)
Couteau de bricolage FALLER (Art. Nr. 170687)

Voor de montage heeft u plasticlijm en Lasercut lijm nodig.

Wij adviseren:

FALLER-plasticlijm EXPERT (Art. Nr. 170492)
FALLER-Lasercut lijm (Art. Nr. 170494)
FALLER EXPERT RAPID (Art. Nr. 170500)
FALLER-speciaal zijknijptang (Art. Nr. 170688)
FALLER-knutselmes (Art. Nr. 170687)

2 Auf allen Anfangsseiten sind die Spritzlinge aufgeführt, die man für die folgenden Bauabschnitte benötigt.

Alle angefangenen Spritzlinge nach Gebrauch unbedingt wieder zurück in die dazugehörige Tüte legen, um die nötige Übersicht beizubehalten.

On all first pages you will find a list of the moulded parts that are required for the sections of construction that follow.

Every moulded part you have started to use should imperatively be put back in the corresponding bag, after use, to maintain the general view that is needed.

Sur chaque première page figure la liste des grappes dont on a besoin pour les tranches de travaux qui suivent.

Il faut absolument remettre dans la sachet correspondante, après utilisation, toutes les grappes entamées afin de conserver la vue d'ensemble nécessaire.

Op elke beginpagina staan de spuitgiestukken afgebeeld die voor de volgende bouwfasen nodig zijn.

Elk deels bewerkt spuitgiestuk na gebruik absoluut weer terug doen in de bijbehorende zakje om het noodzakelijke overzicht te kunnen behouden.

Inhalt	Spritzlinge Tüte 1	T 1	Inhalt	Spritzlinge Tüte 3	T 3	Inhalt	Spritzlinge Tüte 5	T 5	Inhalt	Karton				
Contents	Moulded parts bag 1	T 1	Contents	Moulded parts bag 3	T 3	Contents	Moulded parts bag 5	T 5	Contents	Carton				
Contenu	Grappes sachet 1	T 1	Contenu	Grappes sachet 3	T 3	Contenu	Grappes sachet 5	T 5	Contenu	Carton				
Inhoud	Spuitgiestuk zakje 1	T 1	Inhoud	Spuitgiestuk zakje 3	T 3	Inhoud	Spuitgiestuk zakje 5	T 5	Inhoud	Karton				
	3 AB	2 x		7 AB	8 x		10 A	7 x		1 A	F	2 x		
	3 B	1 x		7 B	4 x		10 AB	1 x		1 A	P	4 x		
	3 C	4 x		7 BCD	2 x					1 AB		2 x		
	8 AB	2 x		7 BD	2 x					1 BC		2 x		
	8 B	3 x								1 CD		2 x		
										2 A		4 x		
Inhalt	Spritzlinge Tüte 2	T 2	Inhalt	Spritzlinge Tüte 4	T 4	Inhalt	Spritzlinge Tüte 6	T 6		2 B	H	1 x		
Contents	Moulded parts bag 2	T 2	Contents	Moulded parts bag 4	T 4	Contents	Moulded parts bag 6	T 6		2 B	V	1 x		
Contenu	Grappes sachet 2	T 2	Contenu	Grappes sachet 4	T 4	Contenu	Grappes sachet 6	T 6		11 A		4 x		
Inhoud	Spuitgiestuk zakje 2	T 2	Inhoud	Spuitgiestuk zakje 4	T 4	Inhoud	Spuitgiestuk zakje 6	T 6		12		1 x		
	3 A	2 x		9 ABC	2 x		4 C	4 x		13		1 x		
	3 B	1 x		9 AB	2 x		35 AC	1 x	Inhalt	Tüte 7	T 7	Inhalt	Tüte 8	T 8
	4 AB	2 x		9 B	3 x		35 BC	1 x	Contents	bag 7	T 7	Contents	bag 8	T 8
	5 AB	1 x					36 AB	1 x	Contenu	sachet 7	T 7	Contenu	sachet 8	T 8
	5 B	1 x					36 C	2 x	Inhoud	zakje 7	T 7	Inhoud	zakje 8	T 8
	8 AB	1 x					36 D	2 x						
	8 B	1 x					37 B	1 x						

Bitte beachten Sie: Das Modell der Containerbrücke ist ein reines Standmodell ohne Antrieb. Es ist grundsätzlich in verschiedenen Größen baubar. Sollten Sie das Modell mit Antrieb realisieren möchten, so ist ein speziell entwickeltes Antriebs-Kit, Art. 180290 separat zu erwerben. Dies muss vor dem Bau entschieden werden. **Ein Nachrüsten ist grundsätzlich nicht möglich.** Aktuelle Informationen zum Antriebs-Kit finden Sie unter www.faller.de.

Please note: Our model Container bridge-crane is purely stationary and without any drive. It is always possible to build that model in various sizes. Should you want to realize that model with motorization, then you will have to purchase separately a drive kit, Art. 180290, that was specifically developed to this end. Such decision must be made prior to the assembling procedure.

Retrofitting the model is absolutely not possible. You will find updated information regarding the drive kit on our site www.faller.de.

Veuillez noter: Le modèle Portique à conteneurs est purement stationnaire et sans entraînement. On peut toujours le construire dans différentes tailles. Si vous désirez réaliser ce modèle avec motorisation, il faut acquérir séparément un kit d'entraînement, Art. 180290, spécialement mis au point à cet effet. Il faut aussi prendre cette décision avant d'entreprendre la construction.

Une motorisation ultérieure n'est absolument pas possible. Vous trouverez des informations actualisées sur le kit d'entraînement sur notre site www.faller.de.

Let op: Het model van de containerkraan is puur een stand model en heeft geen aandrijving. Het kan in principe in verschillende groottes worden gebouwd. Als u het model van een aandrijving wilt voorzien, moet een speciaal ontwikkelde aandrijfset, art. 180290, apart worden aangeschaft. Dit moet vóór de bouw worden beslist. **Het achteraf aanbrenge van de aandrijving is in principe niet mogelijk.** Op www.faller.de vindt u actuele informatie over de aandrijfset.

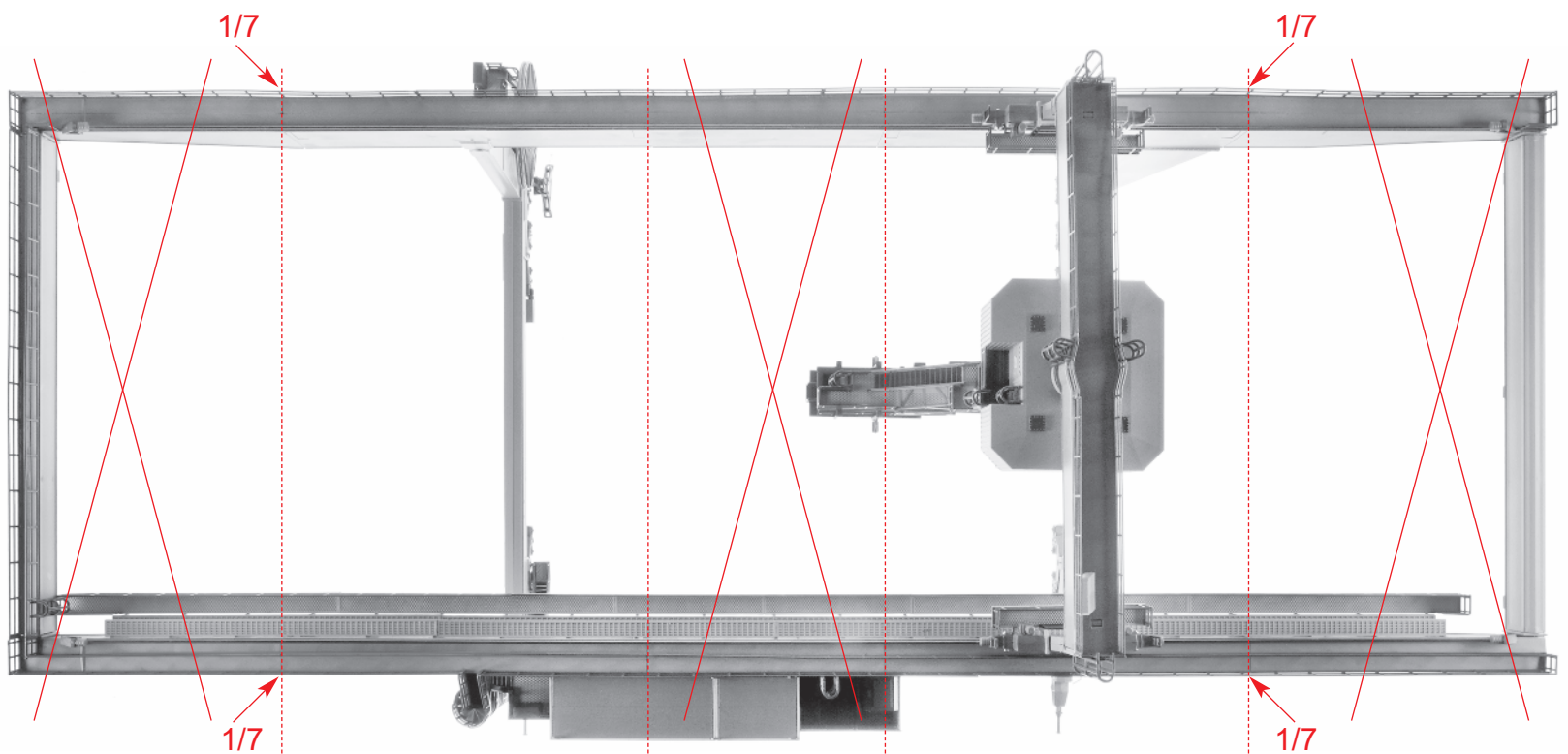

Achtung: Die Containerbrücke ist in verschiedenen Längen baubar. Die Geländer müssen dann entsprechend gekürzt werden.

Caution: The Container bridge-crane can be built with different lengths. Railings must then be shortened accordingly.

Attention: On peut construire le Portique à conteneurs en différentes longueurs. Il faut alors raccourcir les garde-corps de façon correspondante.

Let op: de containerkraan kan in verschillende lengtes worden gebouwd. De balustrades moeten dan passend worden ingekort.

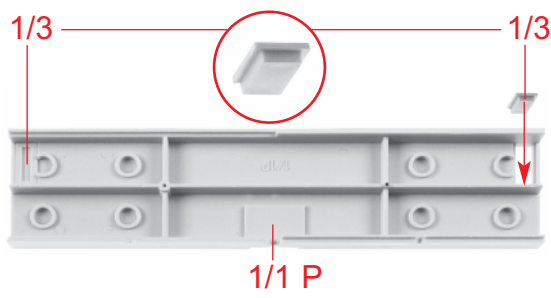

A 4 x

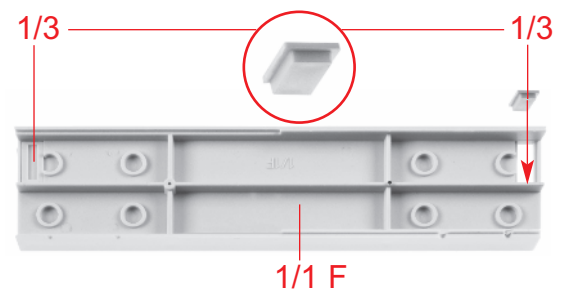

B 4 x

Art. Nr. 180653:
 Beleuchtung nur hier einbauen, liegt nicht bei.
 Only install here illumination, not included.
 Eclairage seulement installer ici, non jointe.
 Verlichting alleen hier installeren, niet bijgevoegd.

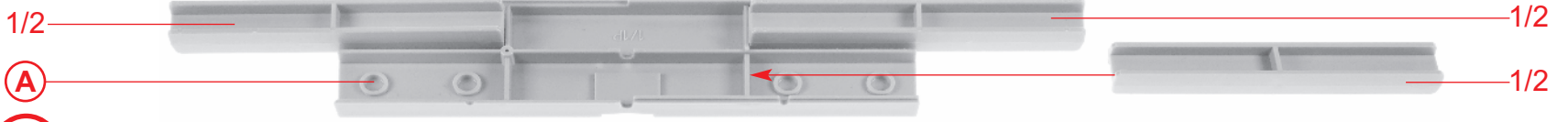
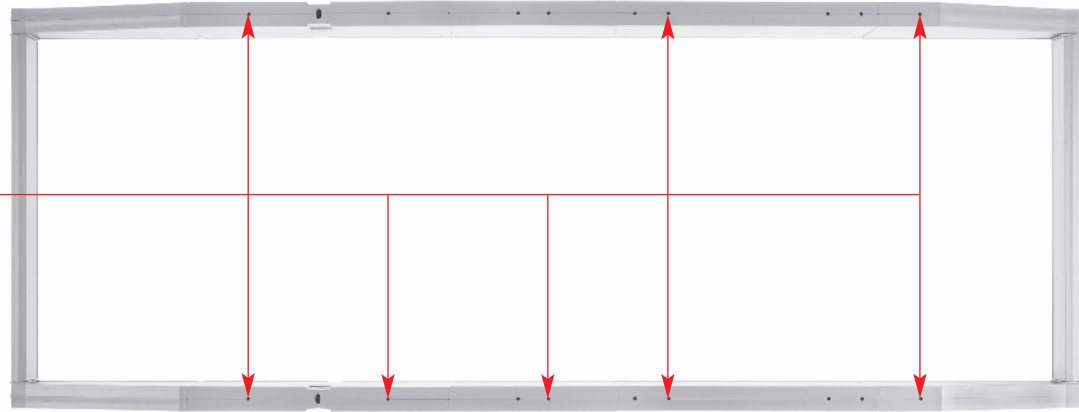

C 2 x

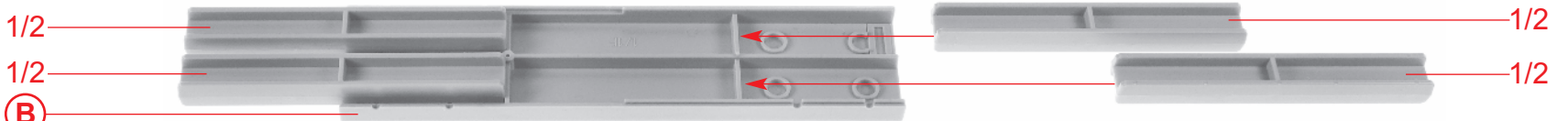

D 2 x

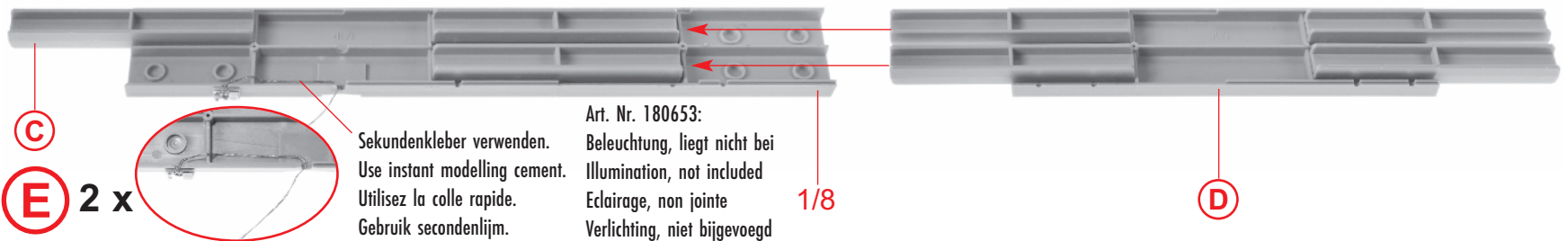

E 2 x

Sekundenkleber verwenden.
 Use instant modelling cement.
 Utilisez la colle rapide.
 Gebruik secondenlijm.

Art. Nr. 180653:
 Beleuchtung, liegt nicht bei
 Illumination, not included
 Eclairage, non jointe
 Verlichting, niet bijgevoegd

Die Kabel der Beleuchtung nicht einklemmen!
 Do not pinch the cables of the lighting!
 Ne pincez pas les câbles de l'éclairage !
 Knijp niet in de draden van de verlichting!

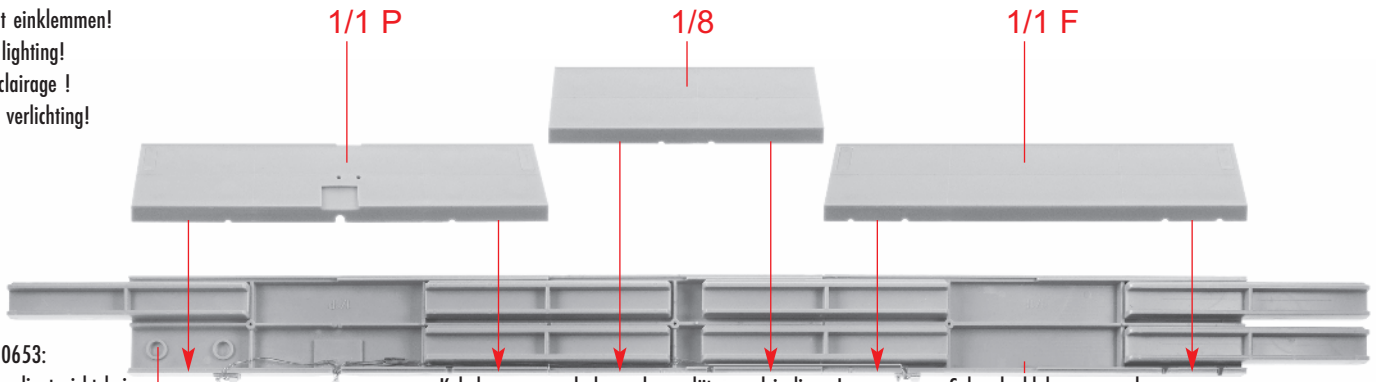

F 2 x

Art. Nr. 180653:
 Beleuchtung, liegt nicht bei
 Illumination, not included
 Eclairage, non jointe
 Verlichting, niet bijgevoegd

Kabel zusammendrehen oder verlöten und isolieren!
 Twist cables together or solder and insulate!
 Tordre les câbles ou les souder et les isoler!
 Stroomdraden aan elkaar draaien of solderen en isoleren!

Sekundenkleber verwenden.
 Use instant modelling cement.
 Utilisez la colle rapide.
 Gebruik secondenlijm.

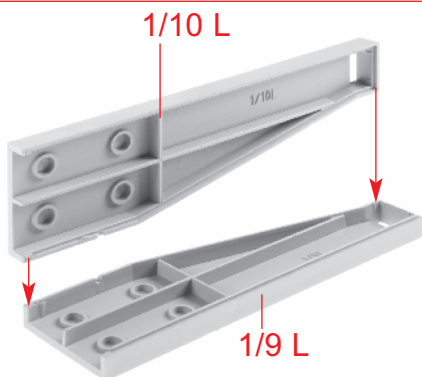

G 2 x

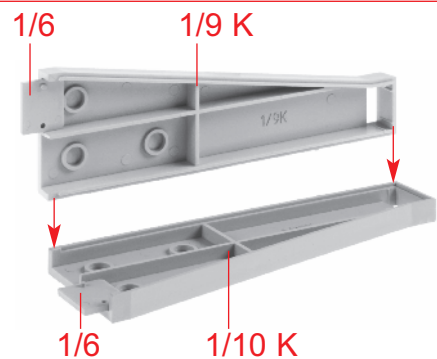

H 2 x

4

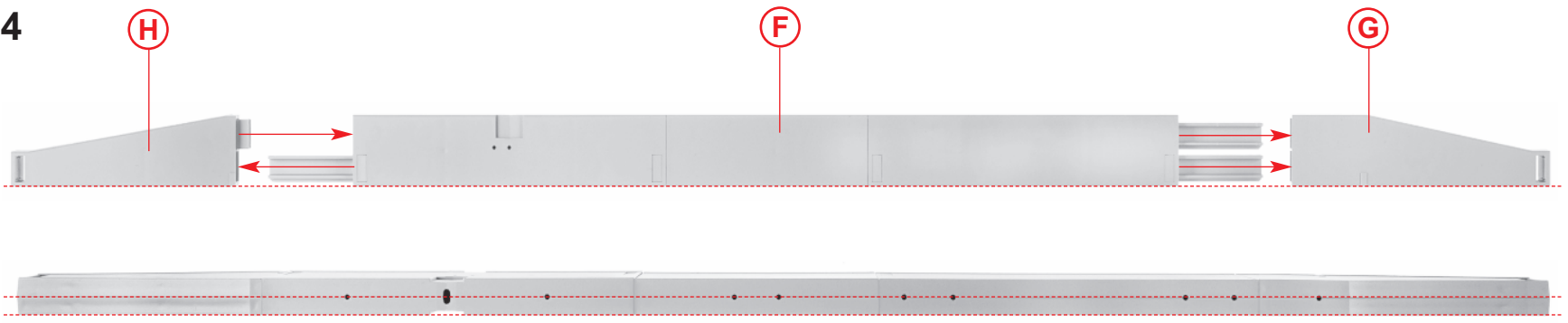

I 2 x

Klebestellen gut abtrocknen lassen!
 Allow glue joints to dry well!
 Laisser bien sécher les points de collage!
 Alle gelijmde punten goed laten drogen!

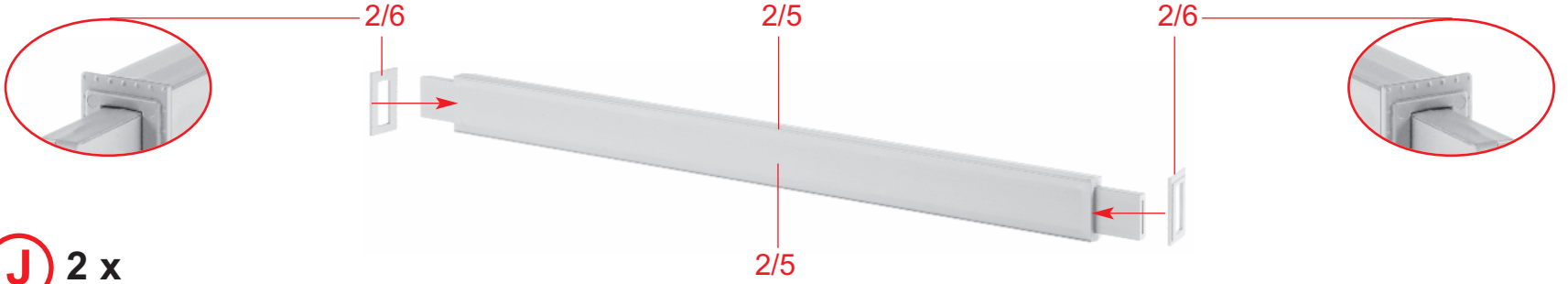

J 2 x

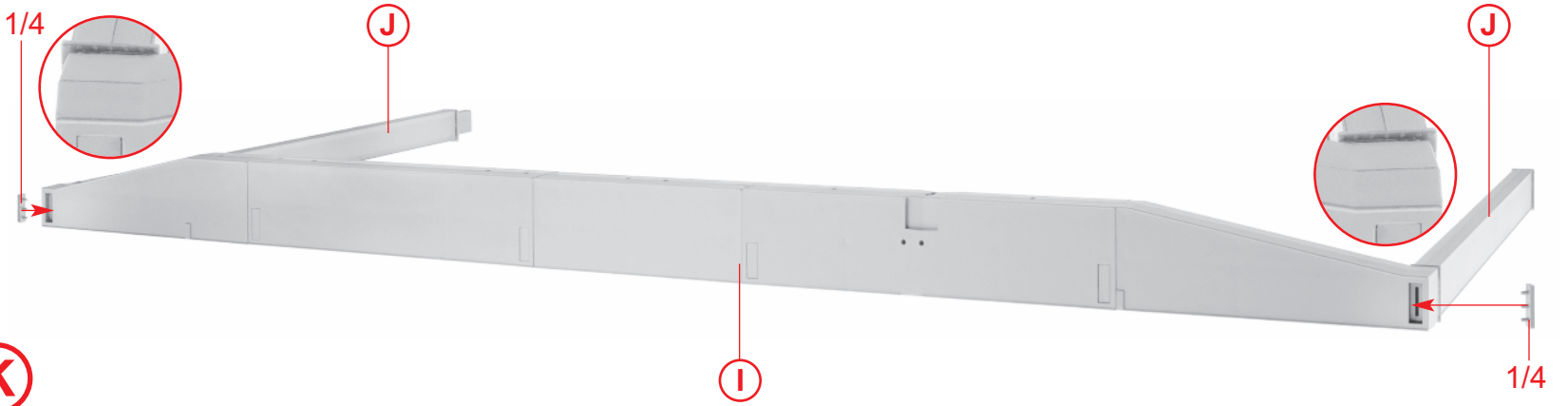

K

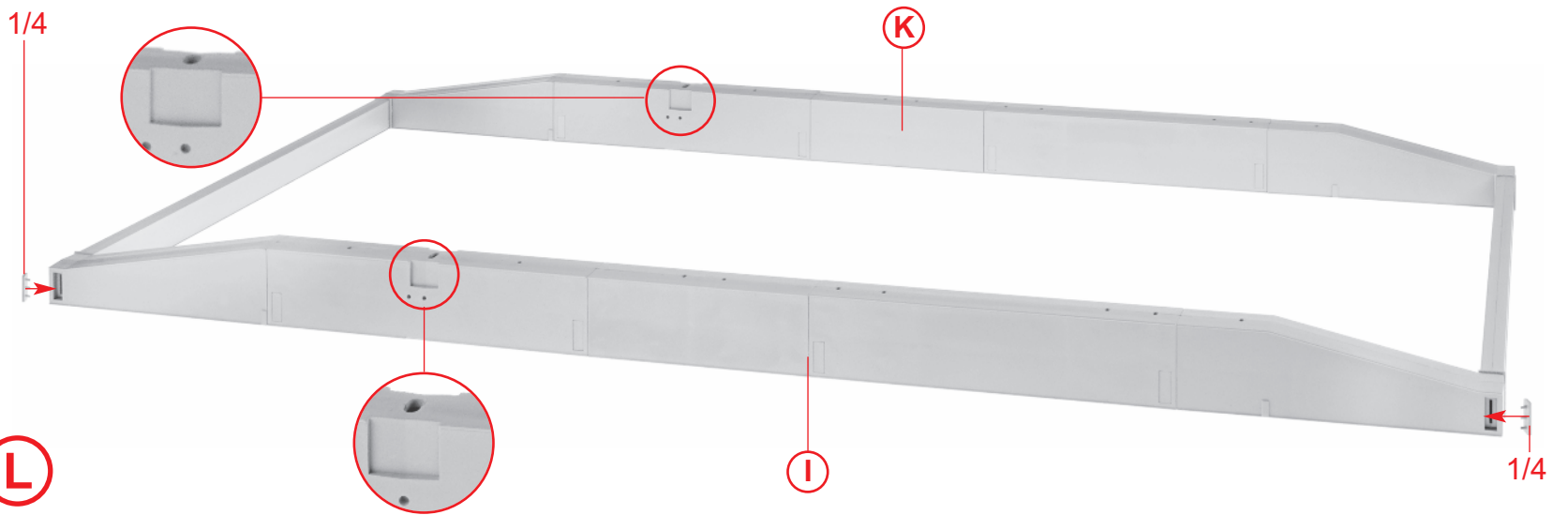

L

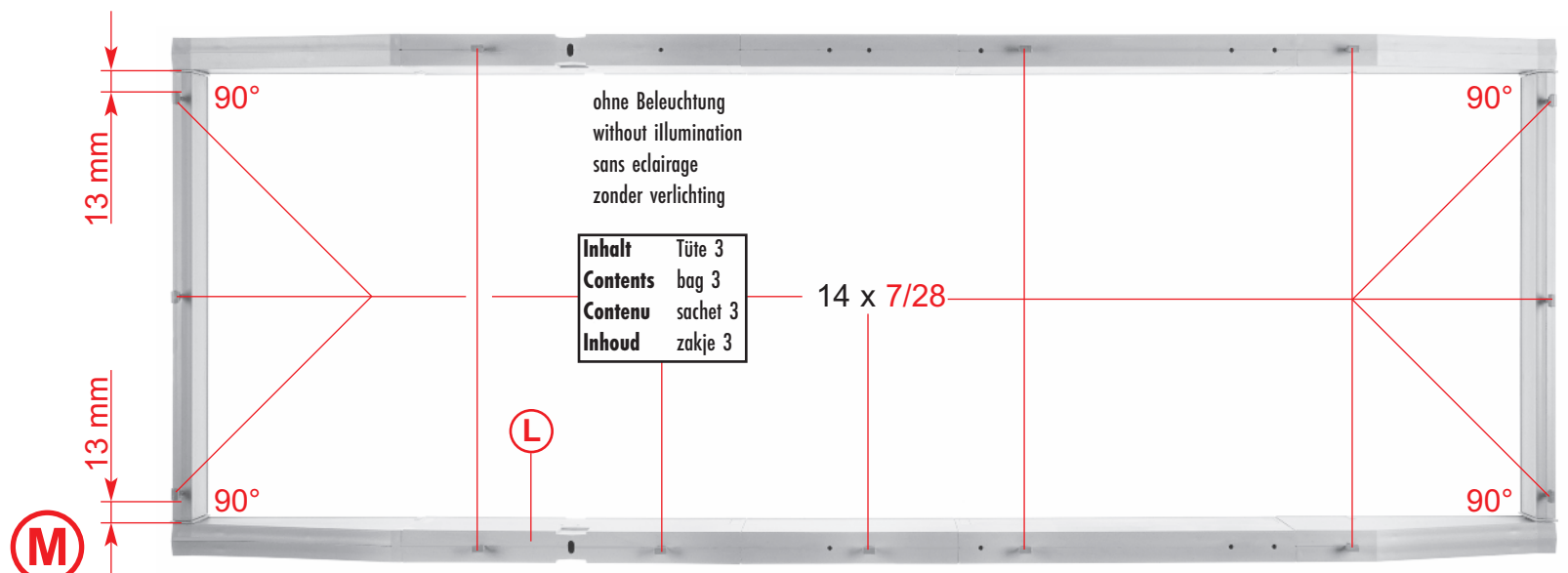

M

mit Beleuchtung
with illumination
avec éclairage
met verlichting

1/13 1/12

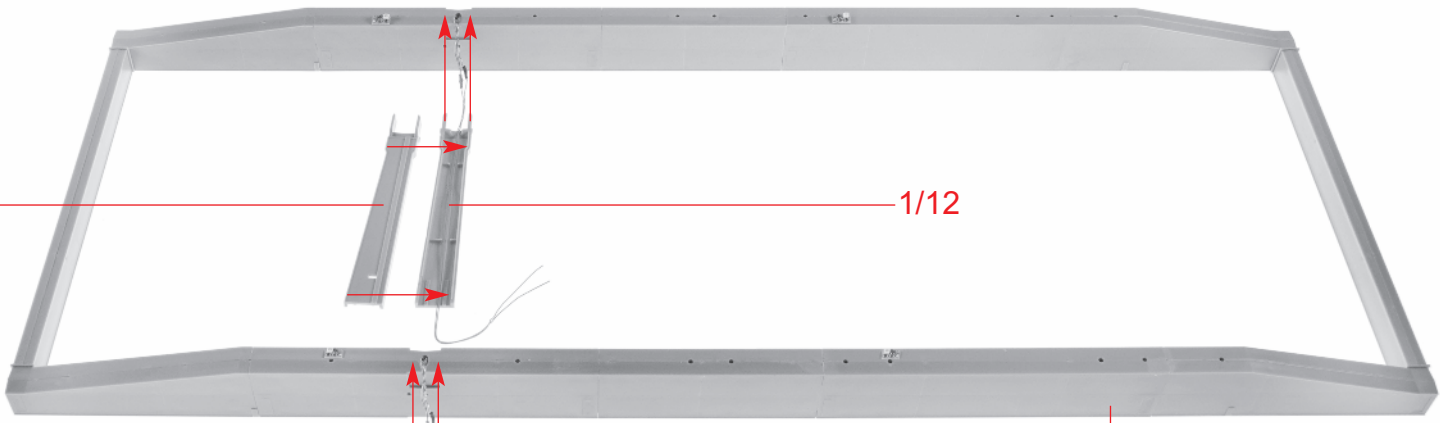

1/13 1/12

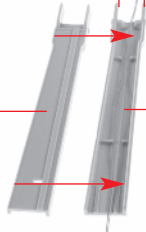

Die Kabel der Beleuchtung nicht einklemmen!
Do not pinch the cables of the lighting!
Ne pincez pas les câbles de l'éclairage !
Knijp niet in de draden van de verlichting!

N

M

mit Beleuchtung
with illumination
avec éclairage
met verlichting

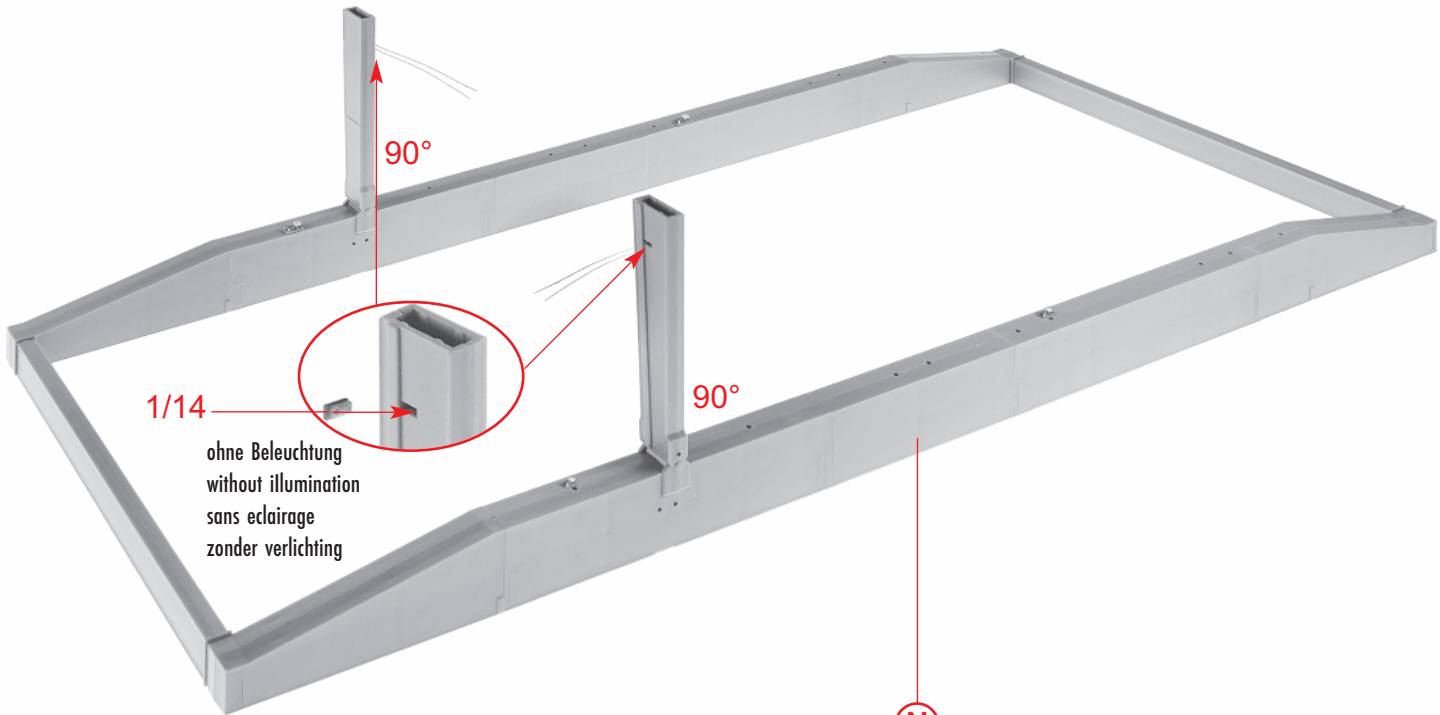

1/14

ohne Beleuchtung
without illumination
sans éclairage
zonder verlichting

O

N

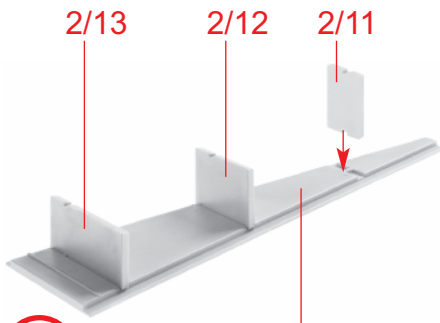

P

2/8 H

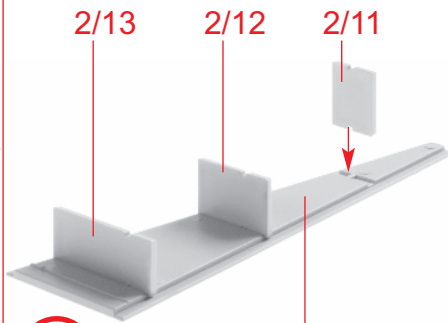

R

2/7 V

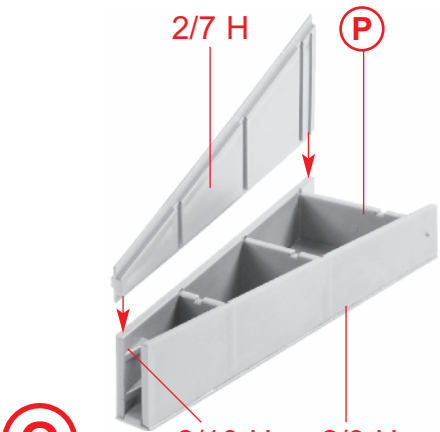

Q

2/10 H 2/9 H

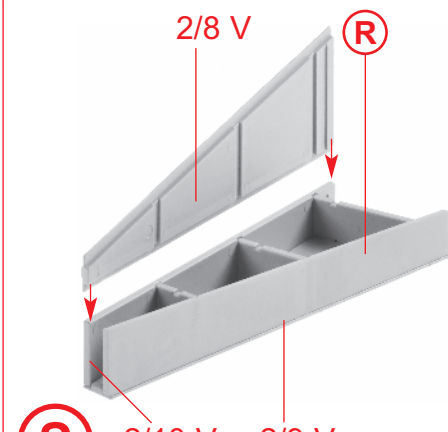

S

2/10 V 2/9 V

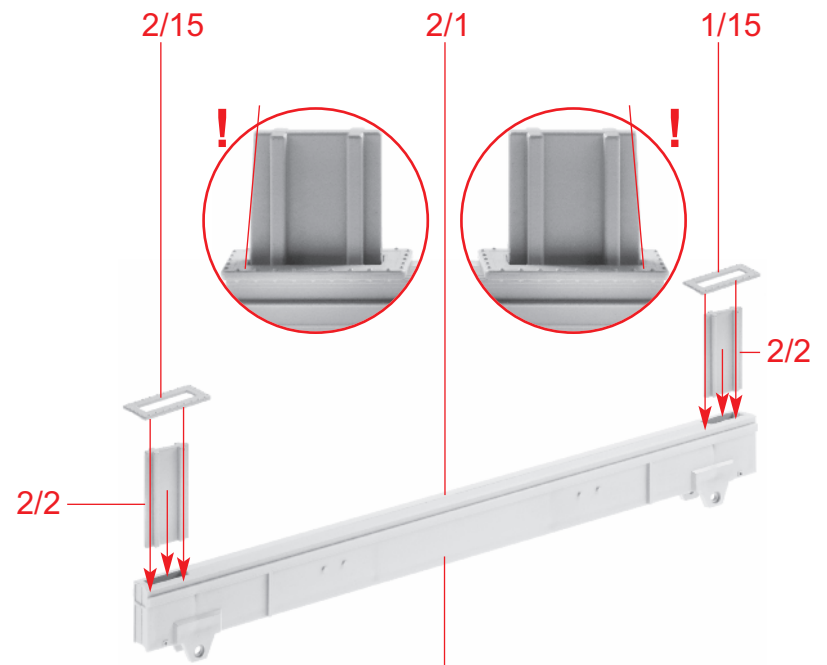

T 2 x

2/1

6 Inhalt Tüte 3+7
 Contents bag 3+7
 Contenu sachet 3+7
 Inhoud zakje 3+7

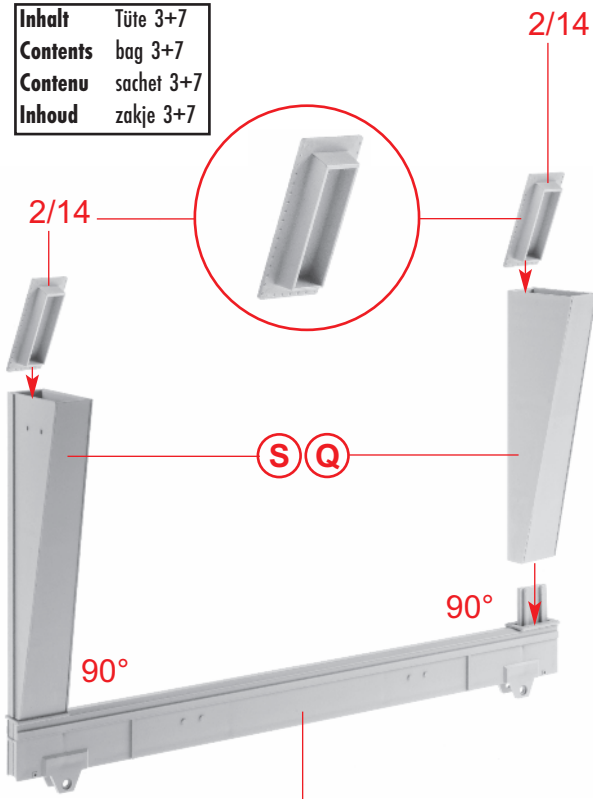

U

T

V

T

U

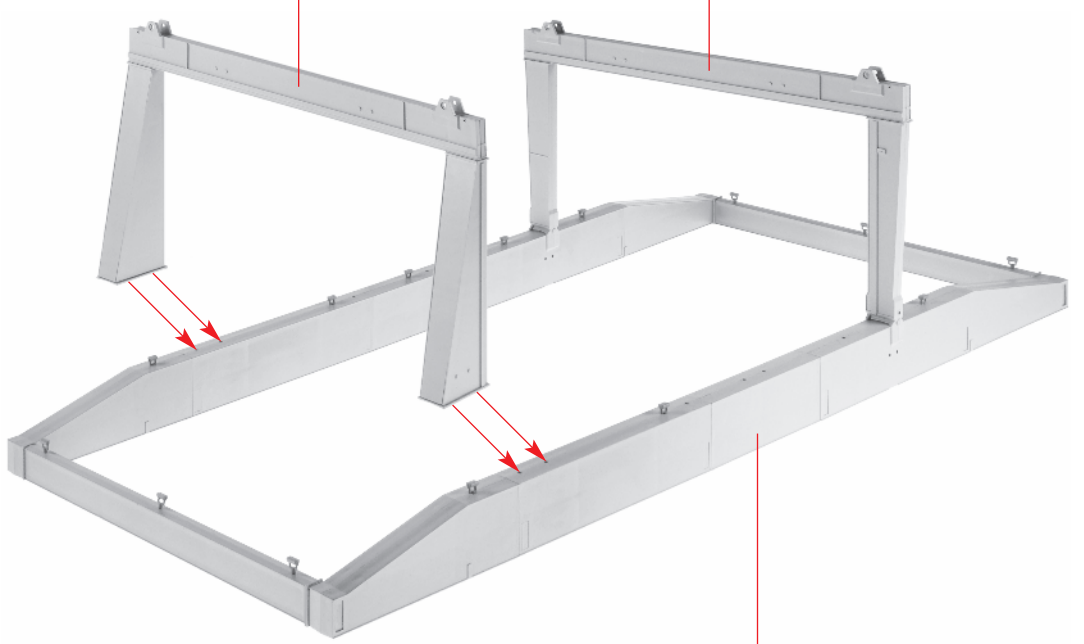

O

ø 8 mm

Inhalt	Tüte 7	Contents	bag 7
Contenu	sachet 7	Inhoud	zakje 7

Nur eindrücken, nicht kleben.
 Press in only, do not glue.
 Ne pas enfoncer, ne pas coller.
 Alleen indrukken, niet lijmen.

7/10 (T 3)

Nur wenig Sekundenkleber verwenden!
 Use only a little instant modelling cement!
 Utilisez seulement un peu de colle rapide !
 Gebruik slechts een beetje secondenlijm!

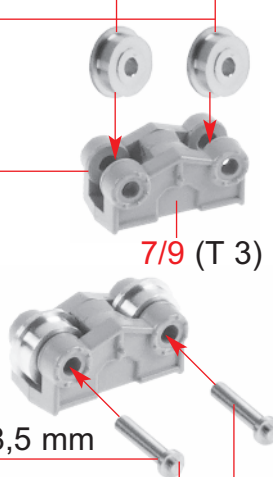

W 8 x

Inhalt	Tüte 7	Contents	bag 7
Contenu	sachet 7	Inhoud	zakje 7

ø 8 mm

Inhalt	Tüte 7	Contents	bag 7
Contenu	sachet 7	Inhoud	zakje 7

Nur eindrücken, nicht kleben.
 Press in only, do not glue.
 Ne pas enfoncer, ne pas coller.
 Alleen indrukken, niet lijmen.

7/10 (T 3)

Nur wenig Sekundenkleber verwenden!
 Use only a little instant modelling cement!
 Utilisez seulement un peu de colle rapide !
 Gebruik slechts een beetje secondenlijm!

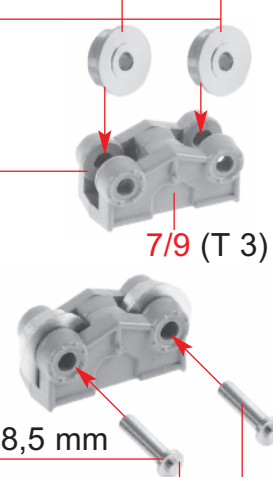

X 4 x

Inhalt	Tüte 7	Contents	bag 7
Contenu	sachet 7	Inhoud	zakje 7

ø 8 mm

Inhalt	Tüte 7	Contents	bag 7
Contenu	sachet 7	Inhoud	zakje 7

Nur eindrücken, nicht kleben.
 Press in only, do not glue.
 Ne pas enfoncer, ne pas coller.
 Alleen indrukken, niet lijmen.

7/3 (T 3)

Nur wenig Sekundenkleber verwenden!
 Use only a little instant modelling cement!
 Utilisez seulement un peu de colle rapide !
 Gebruik slechts een beetje secondenlijm!

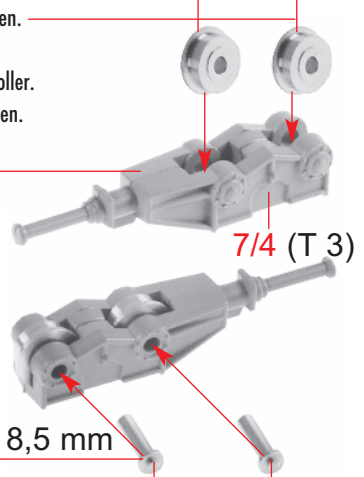

Y 4 x

Inhalt	Tüte 7	Contents	bag 7
Contenu	sachet 7	Inhoud	zakje 7

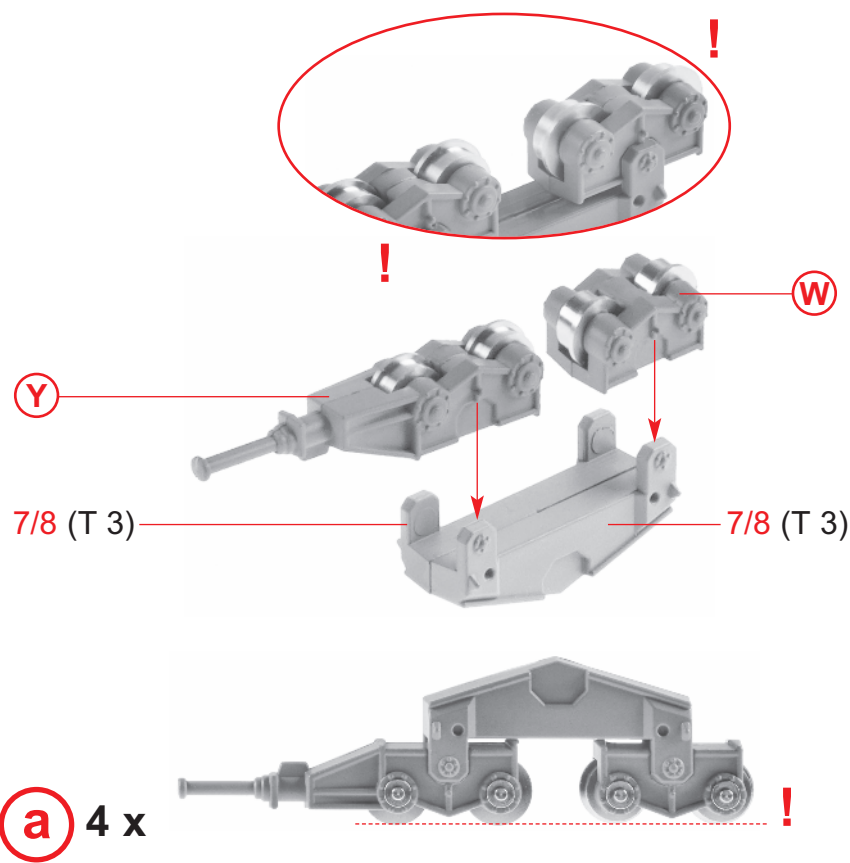

Y

7/8 (T 3)

7/8 (T 3)

a 4 x

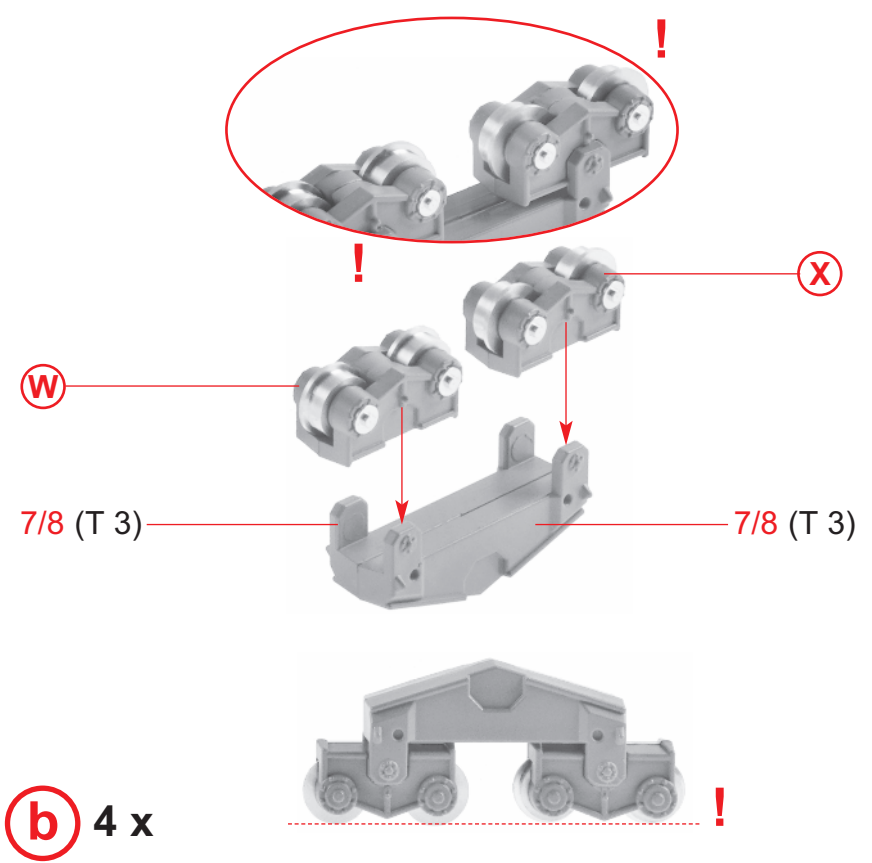

X

W

7/8 (T 3)

7/8 (T 3)

b 4 x

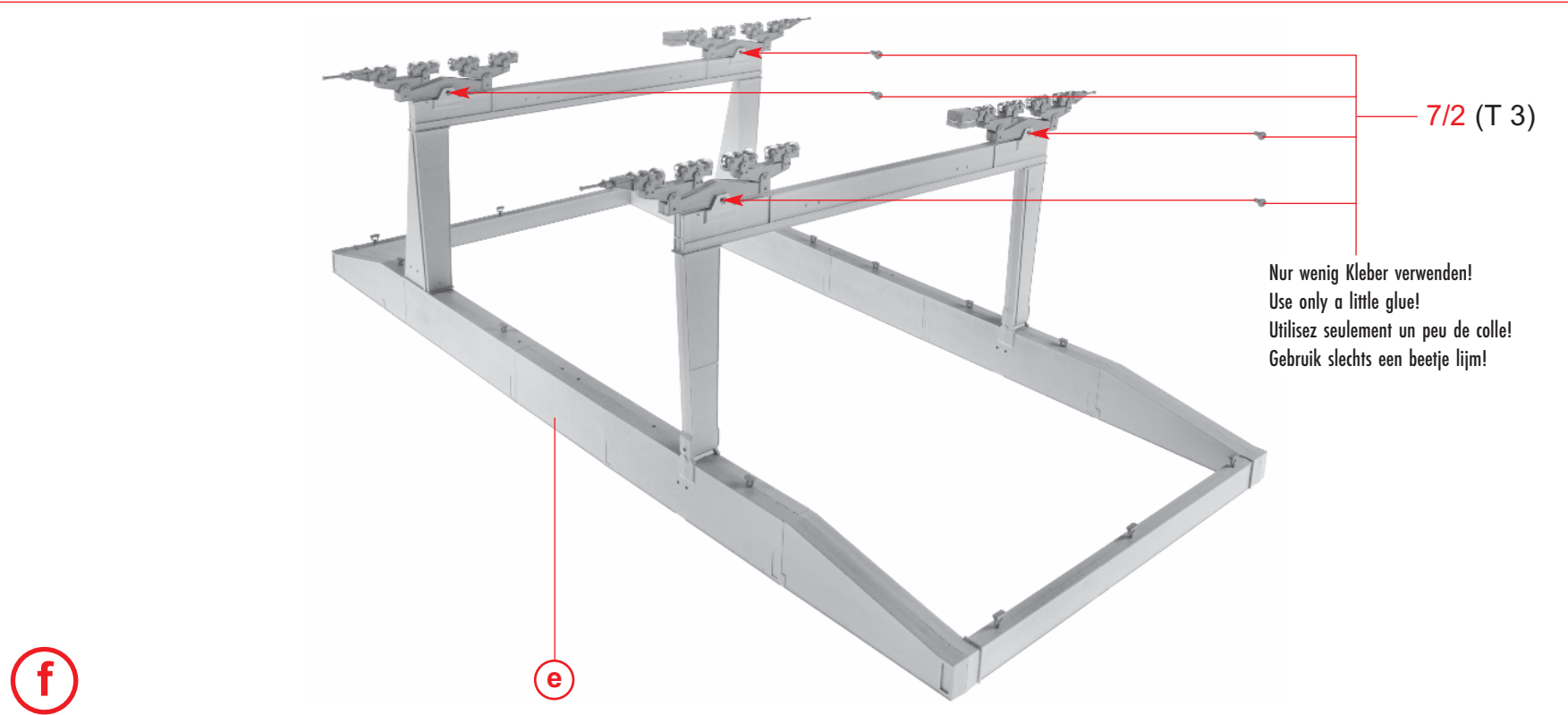
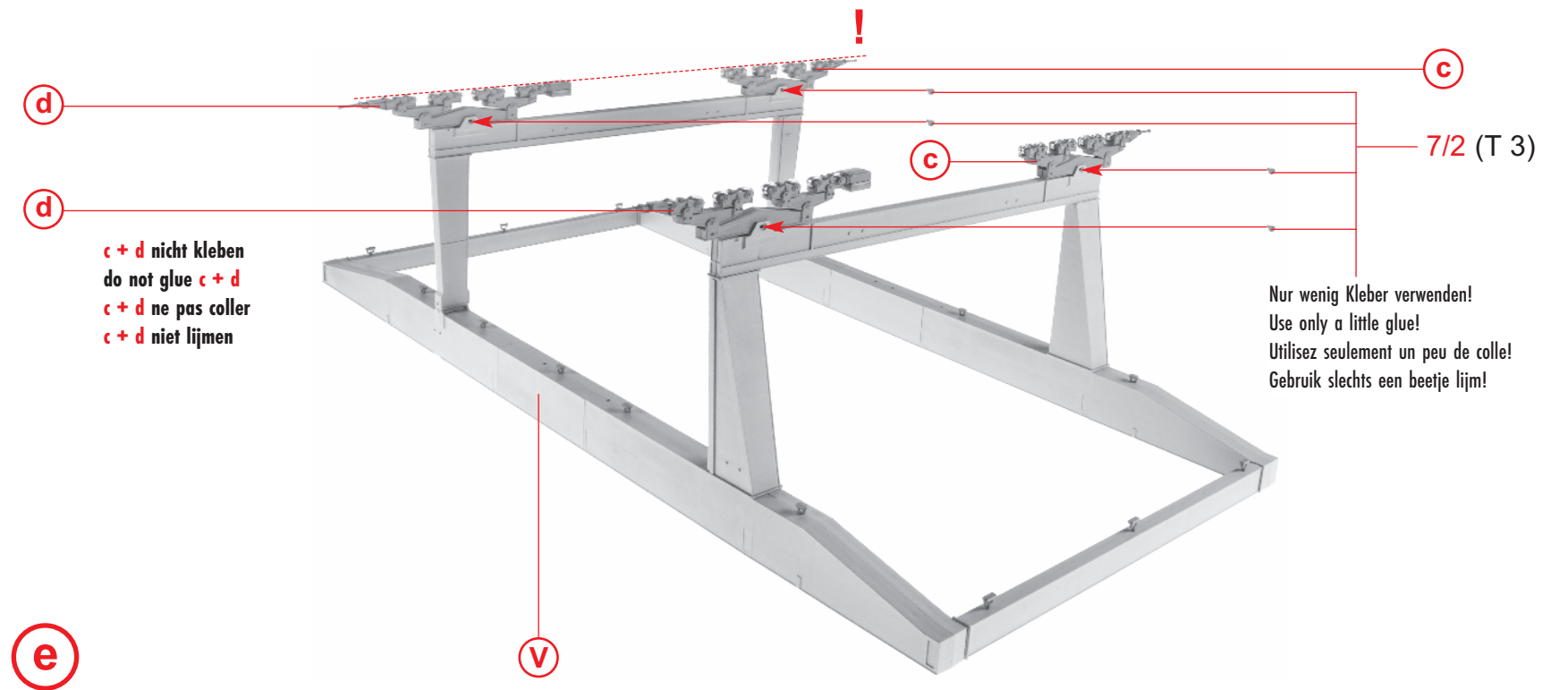
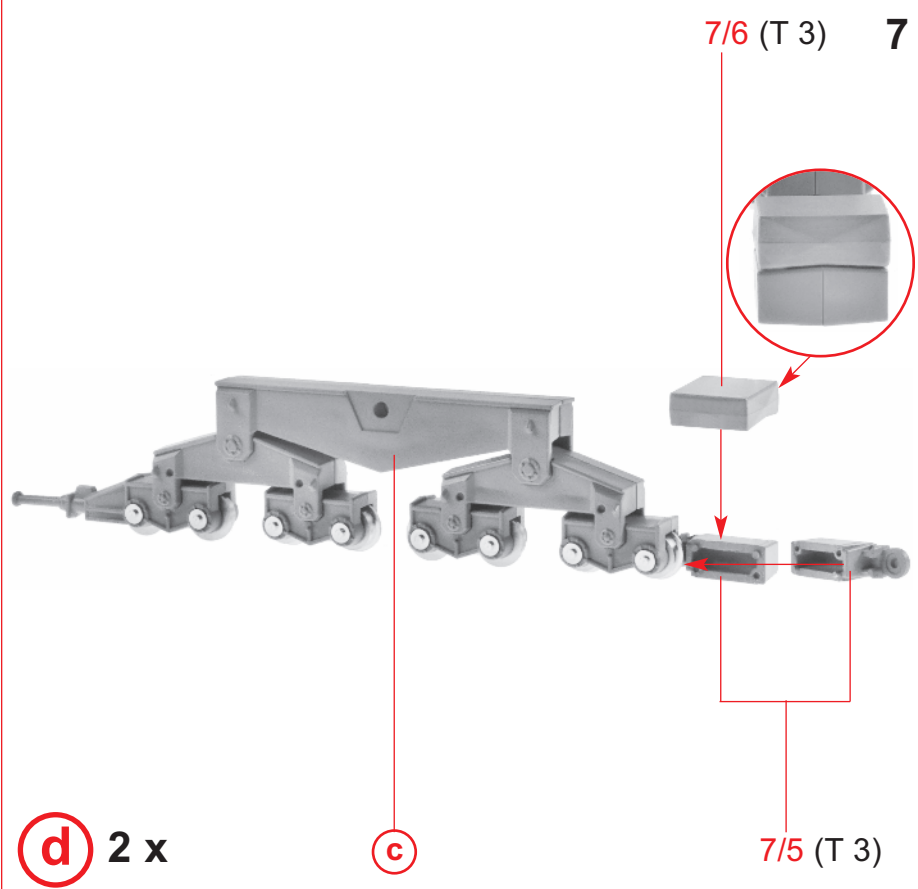
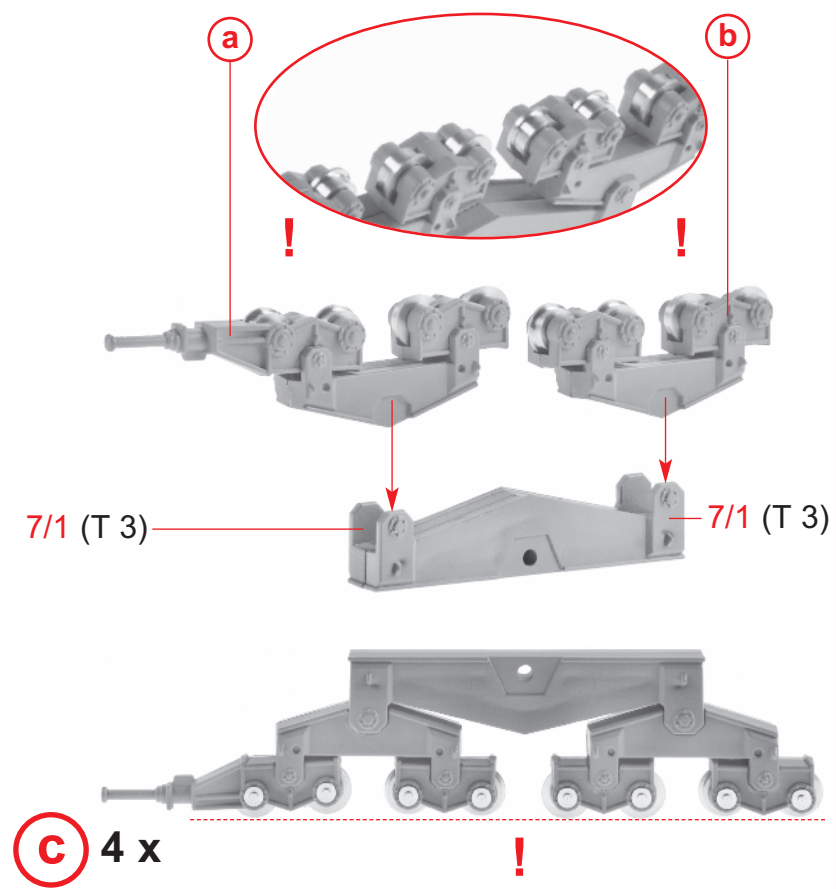

8 Inhalt Tüte 2+3+5+6
 Contents bag 2+3+5+6
 Contenu sachet 2+3+5+6
 Inhoud zakje 2+3+5+6

7/14 (T 3)



7/12 (T 3)

g 6 x

7/14 (T 3)



7/13 (T 3)

h 6 x

7/14 (T 3)

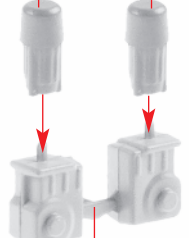

7/11 (T 3)

i 4 x

f

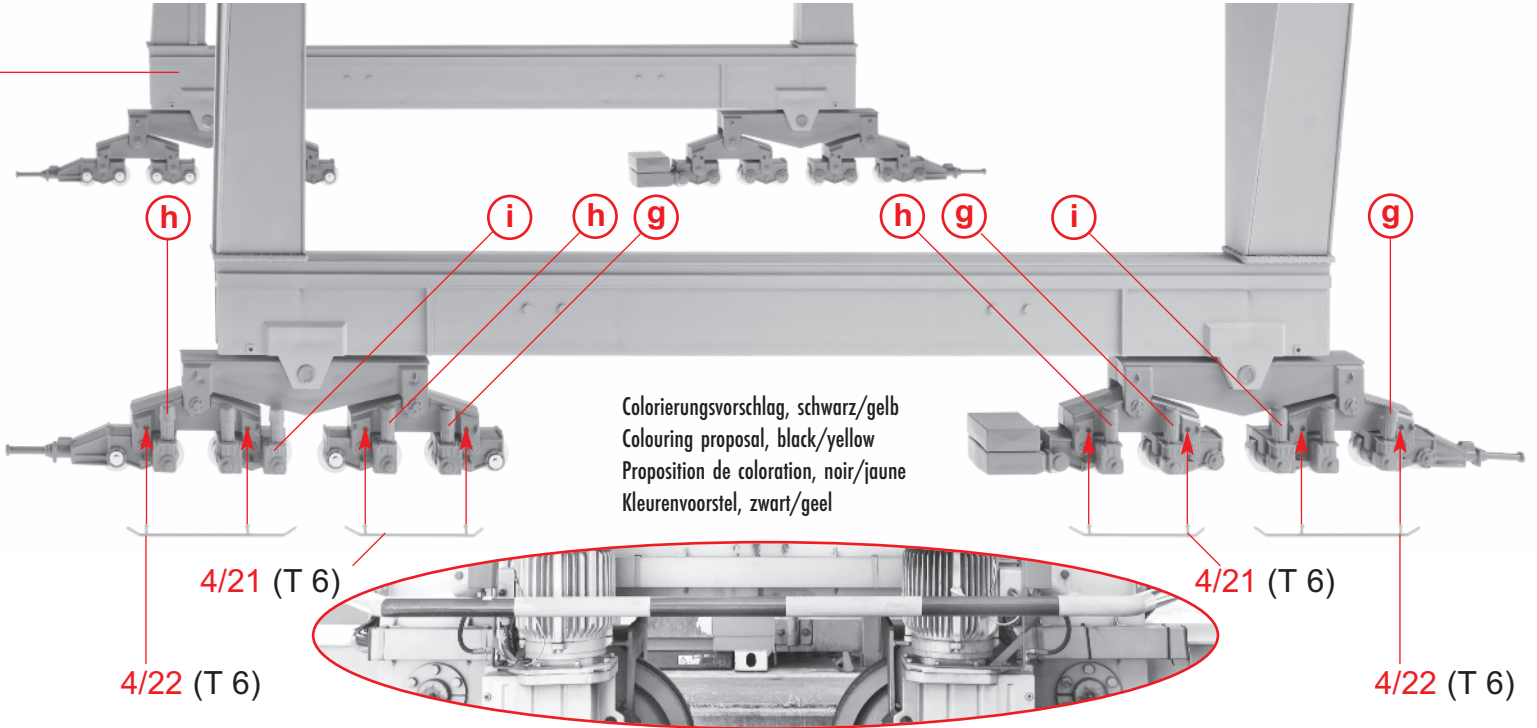

Colorierungsvorschlag, schwarz/gelb
 Colouring proposal, black/yellow
 Proposition de coloration, noir/jaune
 Kleurenvoorstel, zwart/geel

4/21 (T 6)

4/21 (T 6)

4/22 (T 6)

4/22 (T 6)

j

j

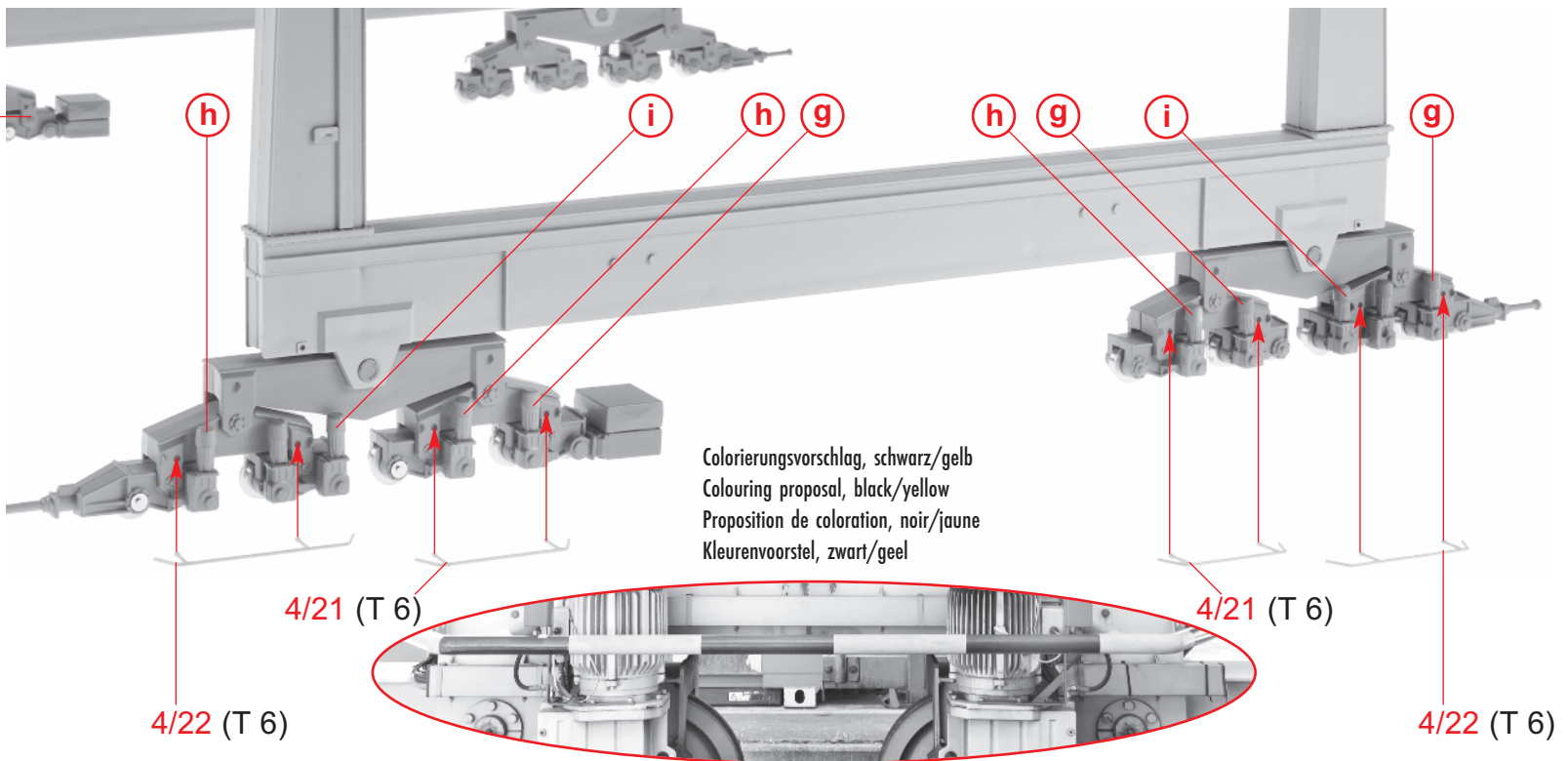

Colorierungsvorschlag, schwarz/gelb
 Colouring proposal, black/yellow
 Proposition de coloration, noir/jaune
 Kleurenvoorstel, zwart/geel

4/21 (T 6)

4/21 (T 6)

4/22 (T 6)

4/22 (T 6)

k

4/12 (T 2)

4/9 (T 2)

4/3 (T 2)

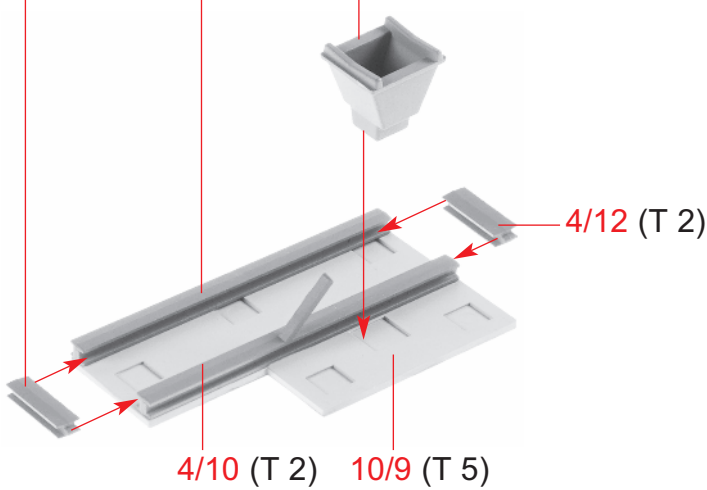

4/10 (T 2)

10/9 (T 5)

l

4/13 (T 2)

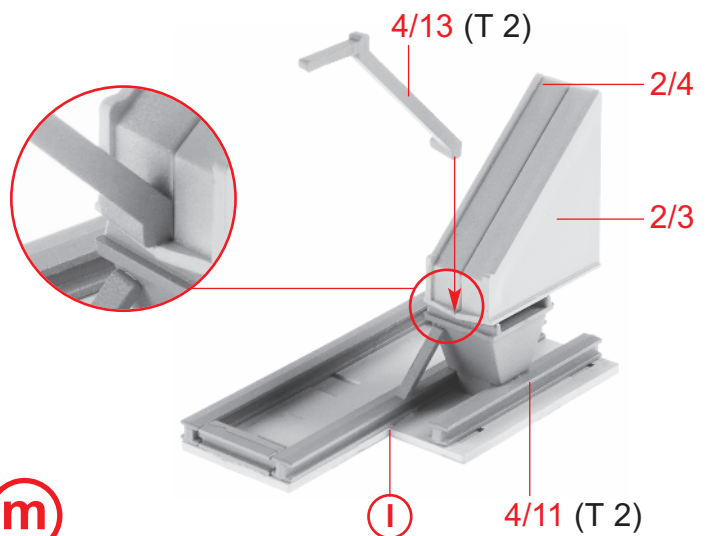

2/4

2/3

4/11 (T 2)

m

Inhalt Tüte 1+2+4
Contents bag 1+2+4
Contenu sachet 1+2+4
Inhoud zakje 1+2+4

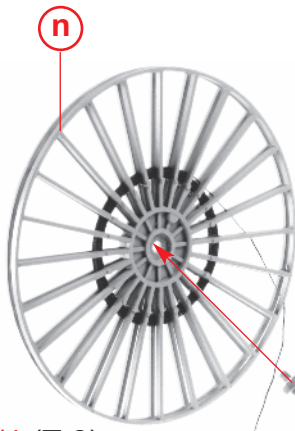
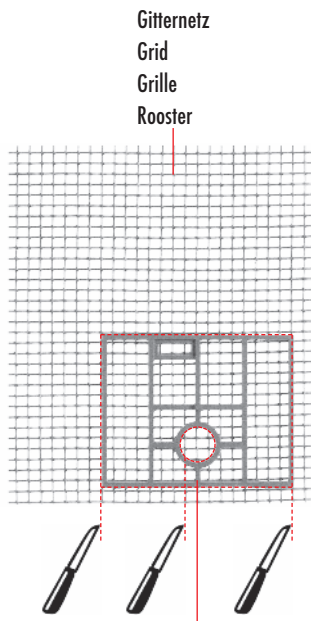
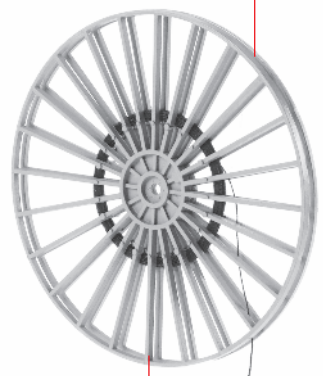

o 4/2 (T 2)

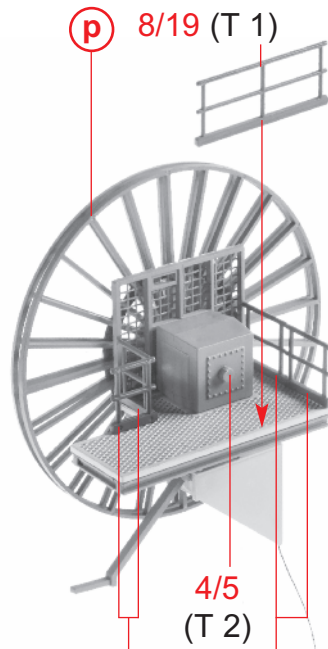

4/4 (T 2) nicht kleben
 do not glue
 ne pas coller
 niet lijmen

p

q

8/8 (T 1) 9/2 (T 4)

n 4/1 (T 2) Faden umwickeln.
 Wrap cord.
 Enrouler le aiguillée.
 Wikkel garen in.

o 4/6 (T 2)

r

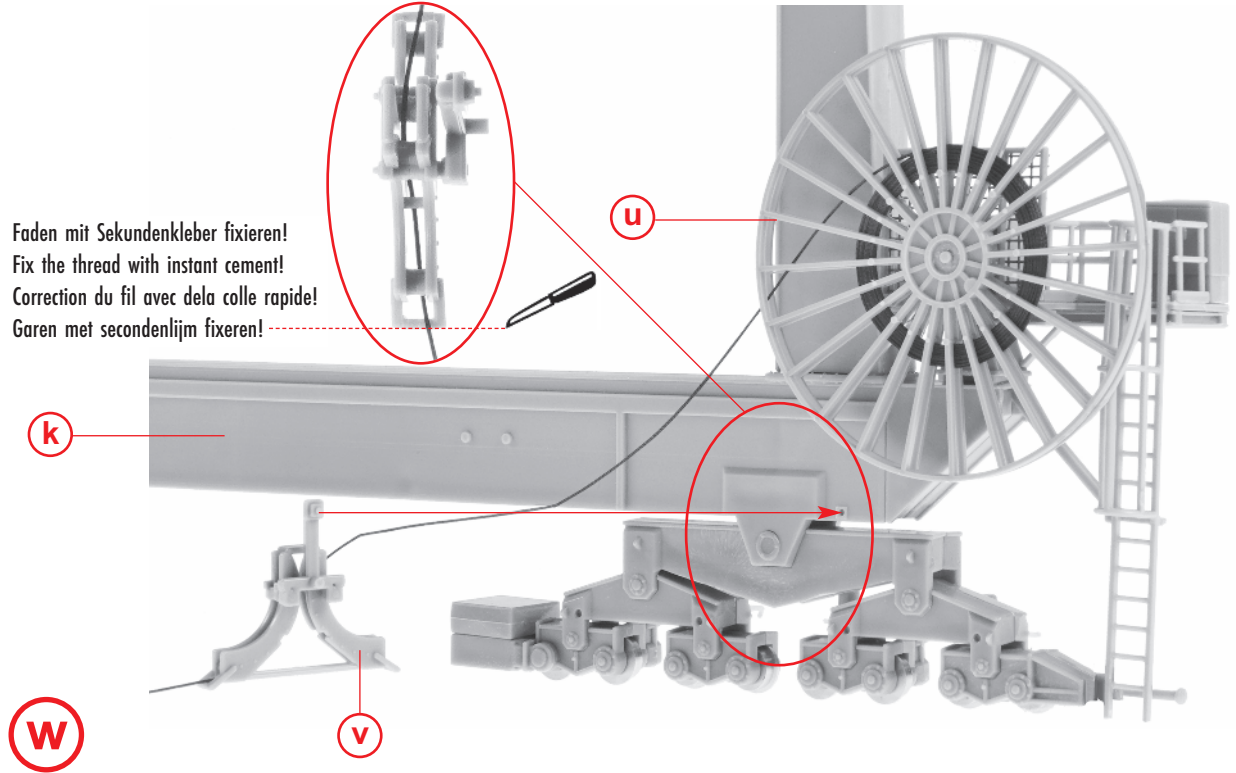
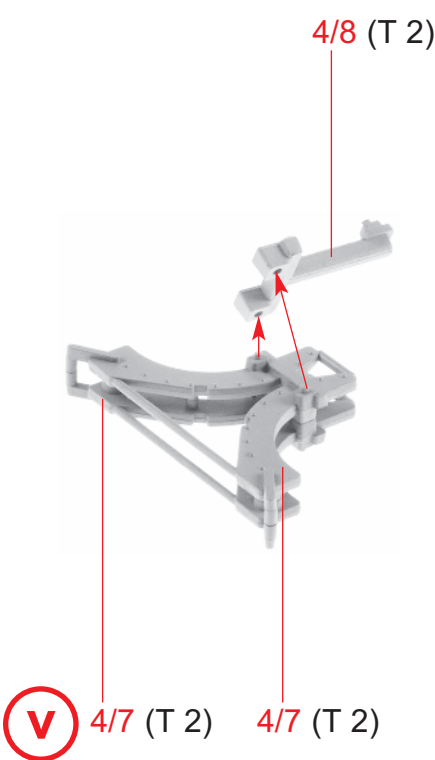
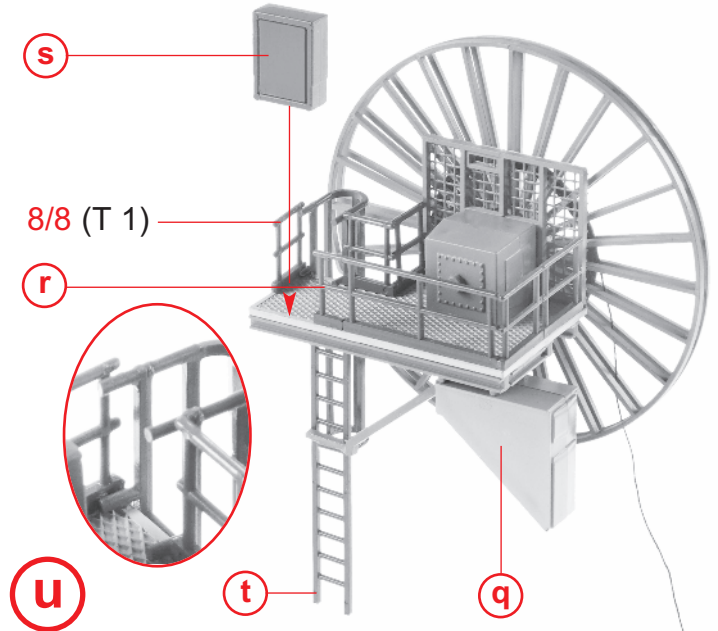
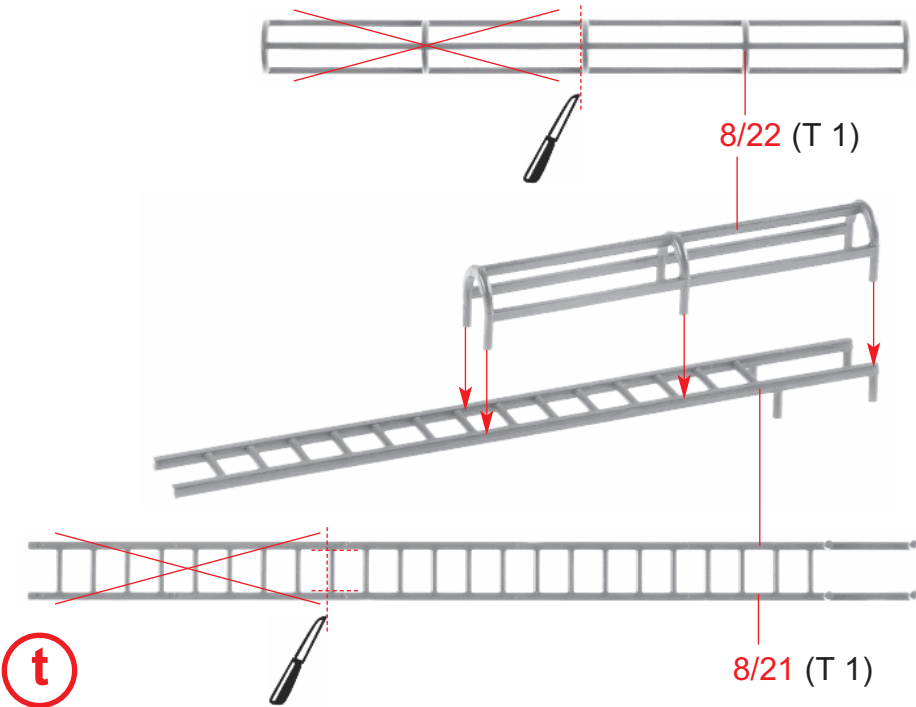
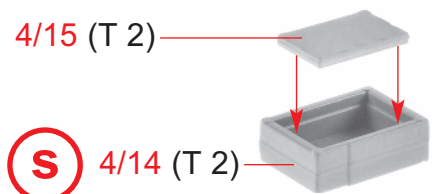
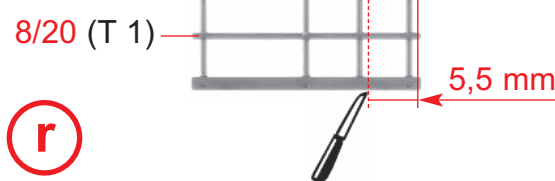

10

Inhalt	Tüte 1+4+5
Contents	bag 1+4+5
Contenu	sachet 1+4+5
Inhoud	zakje 1+4+5

10/7 (T 5)

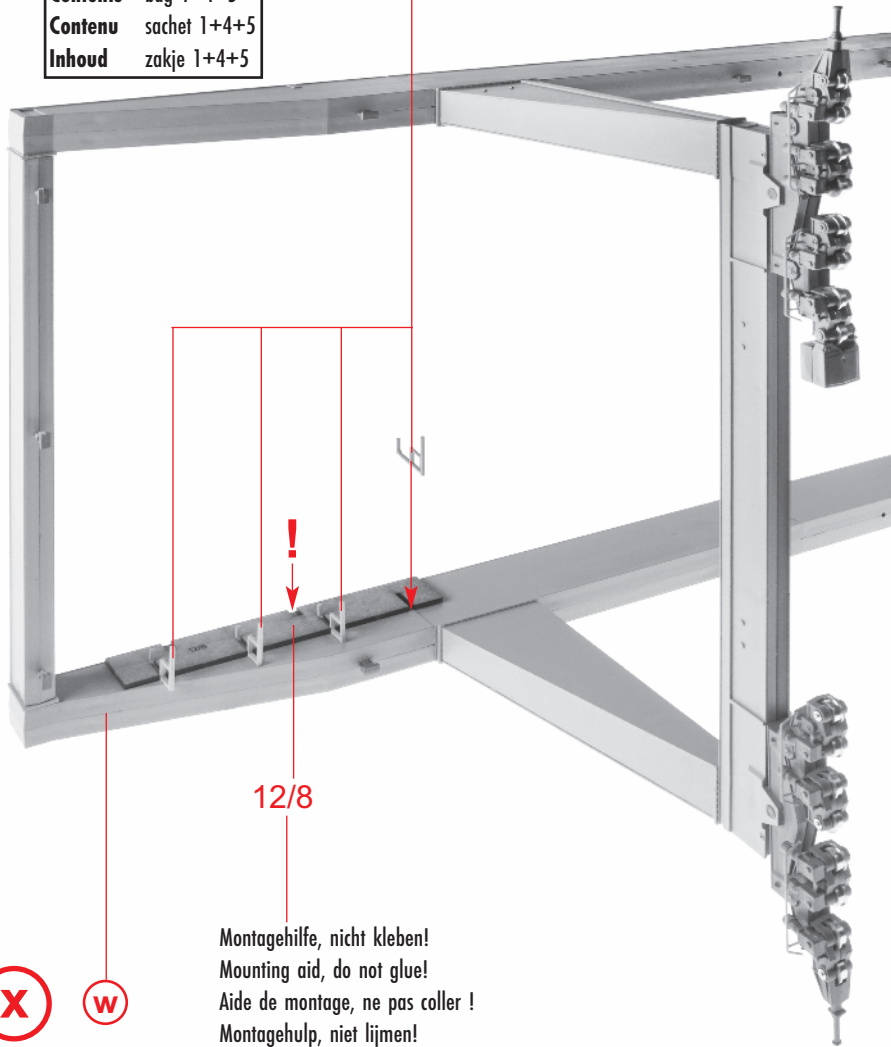

10/7 (T 5)

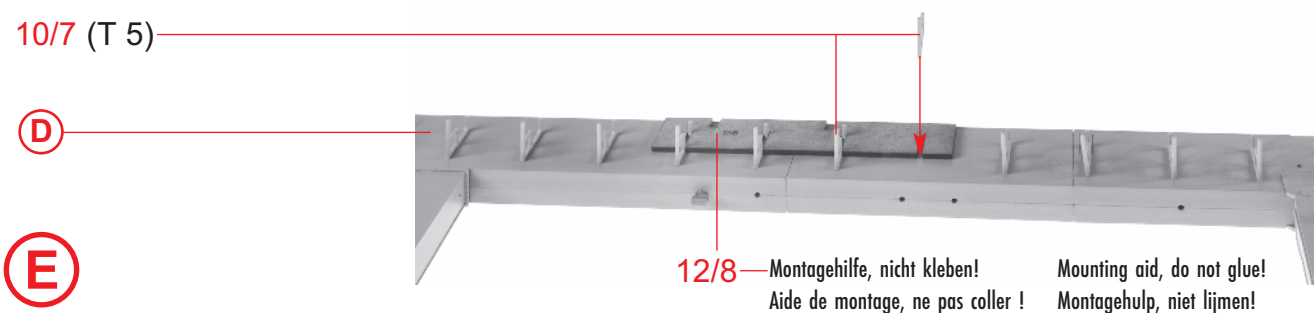
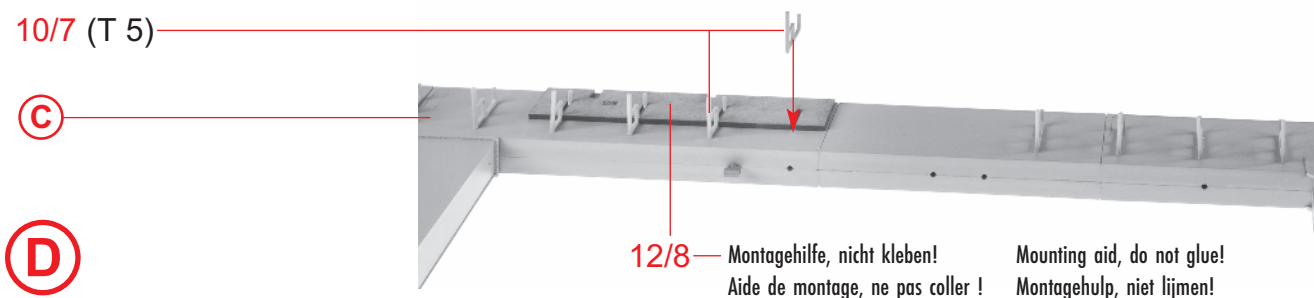
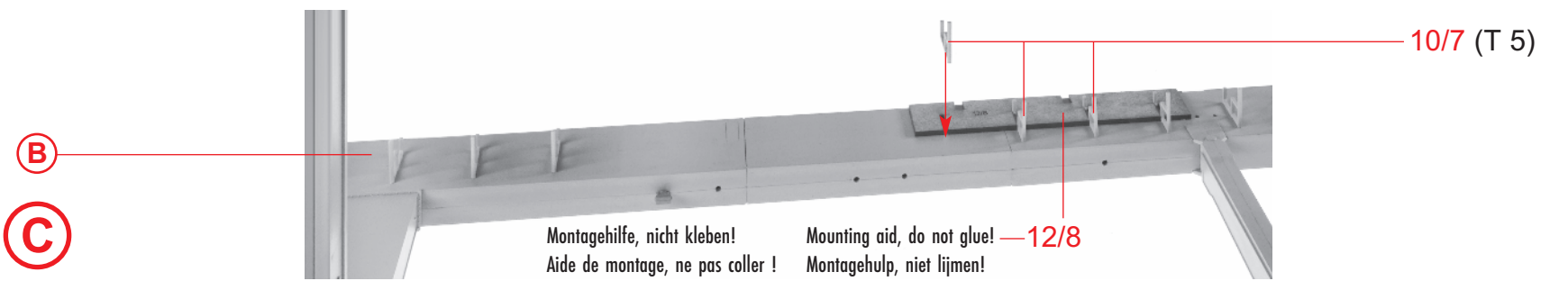
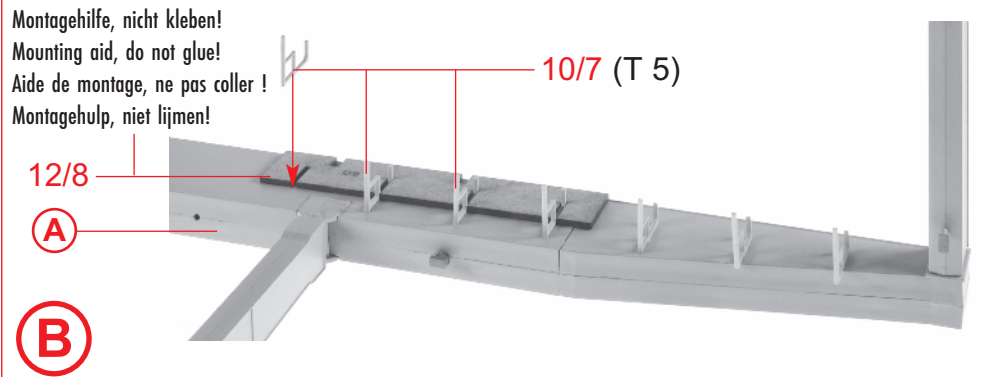
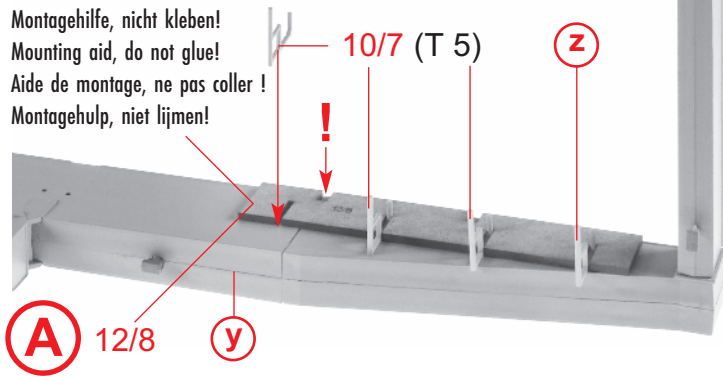
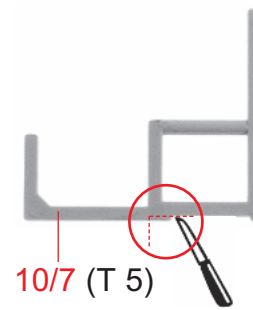
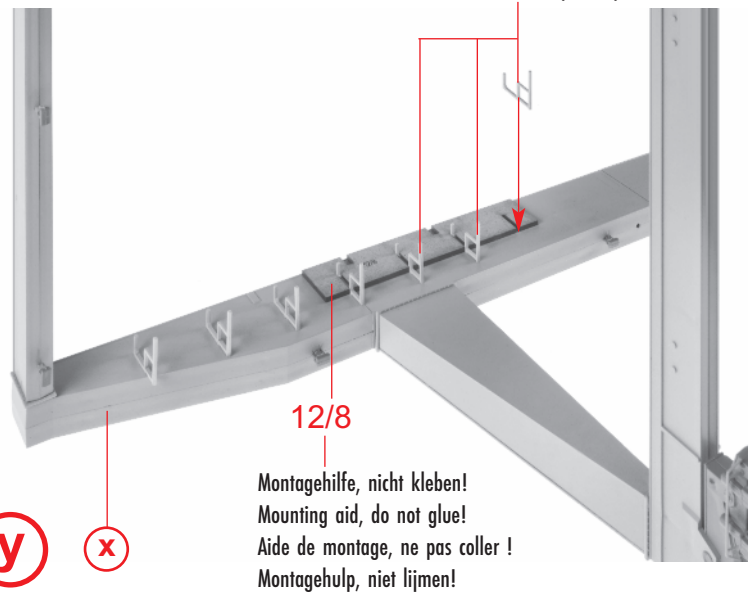

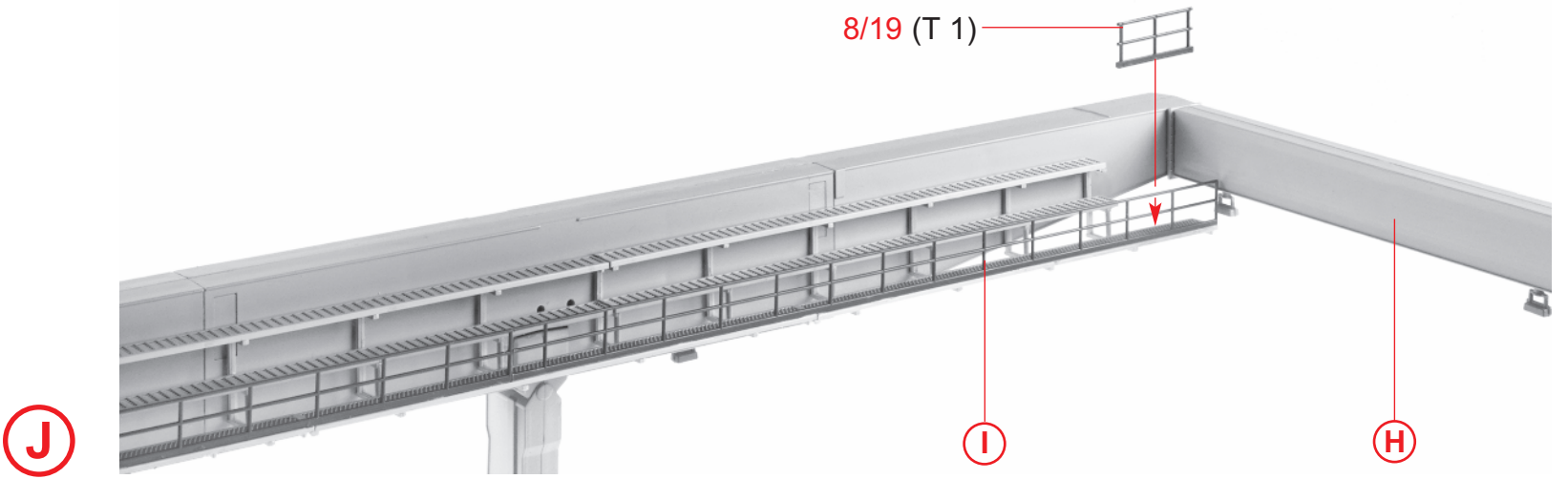
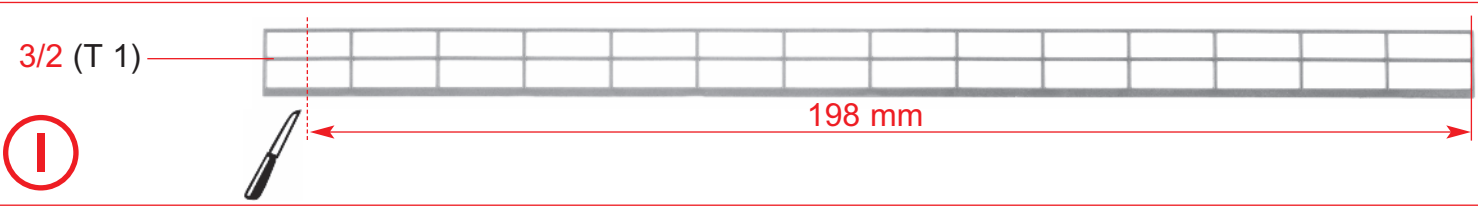
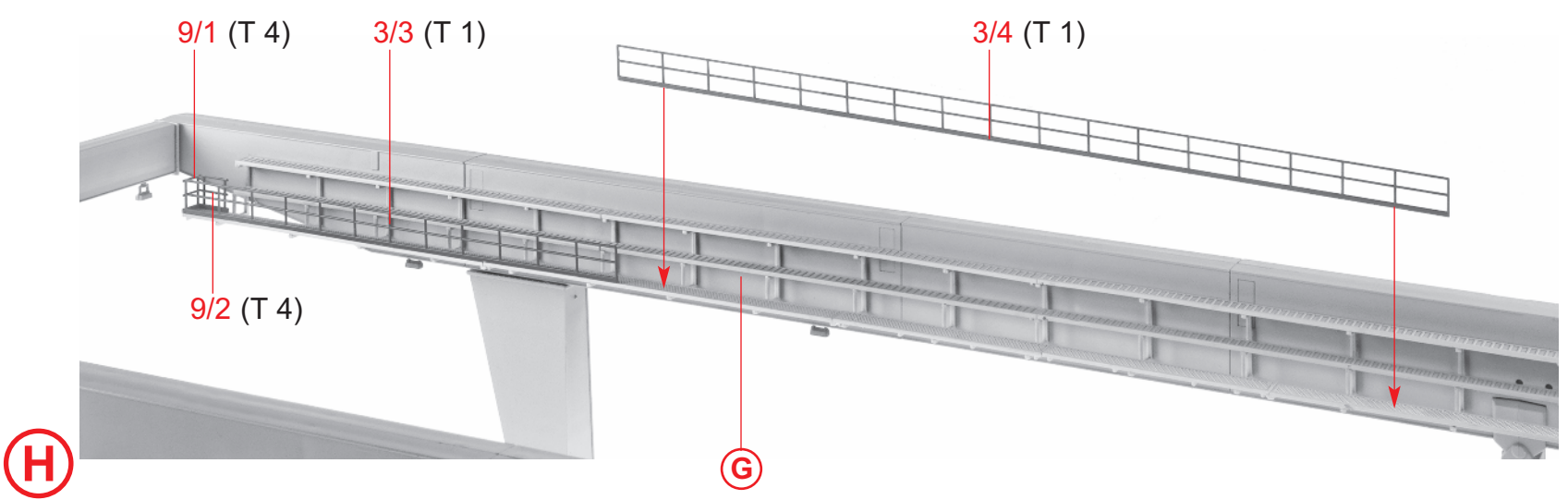
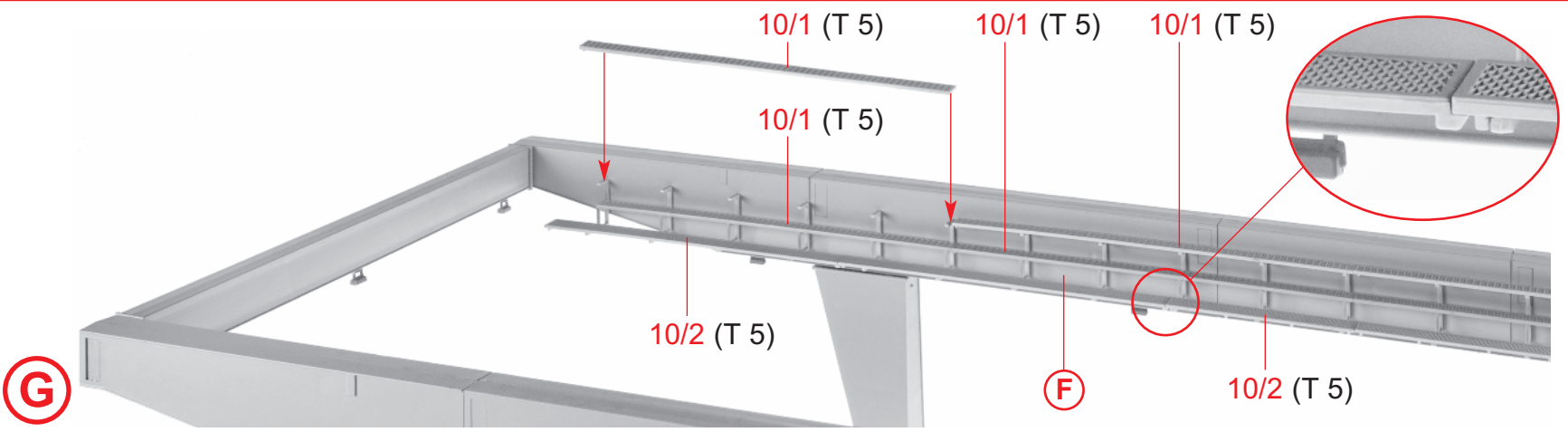
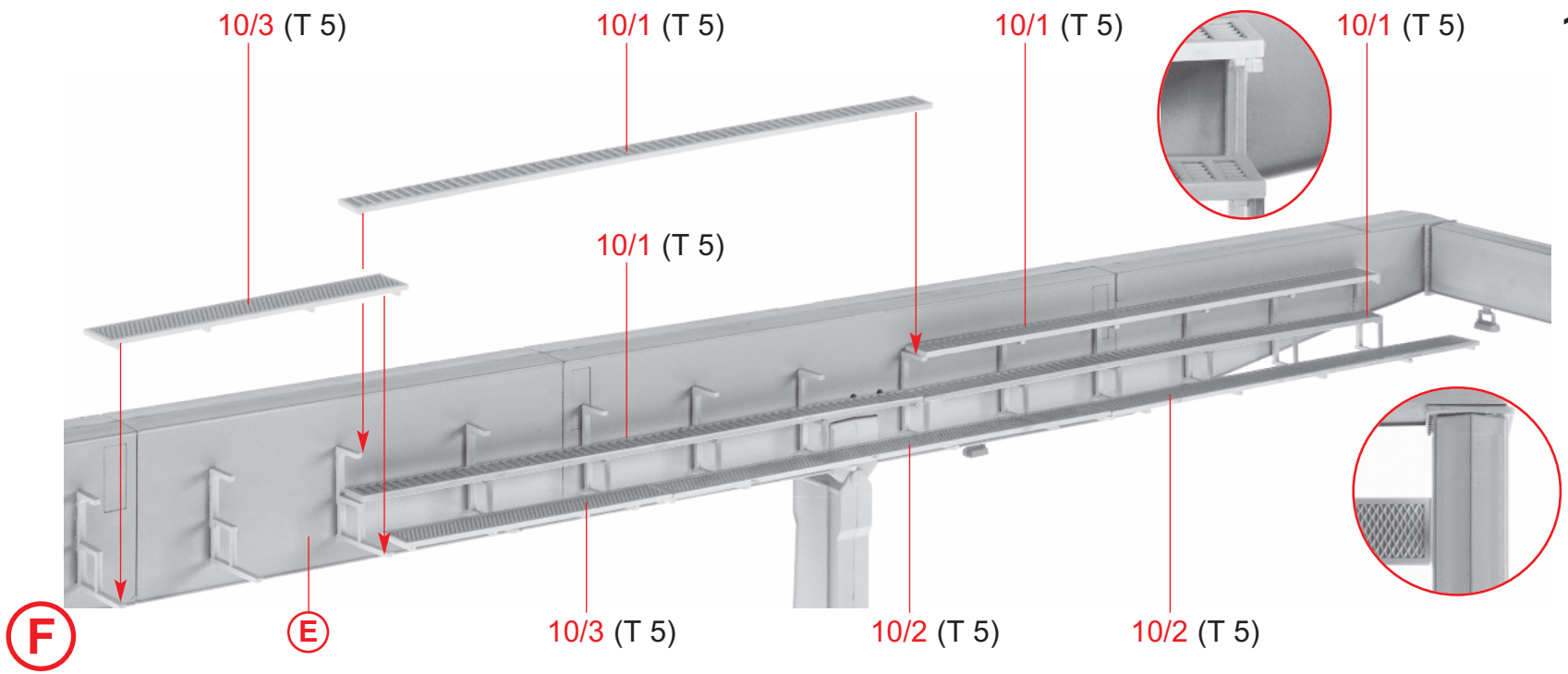

12

Inhalt	Tüte 1+2+3+4+5+6
Contents	bag 1+2+3+4+5+6
Contenu	sachet 1+2+3+4+5+6
Inhoud	zakje 1+2+3+4+5+6

36/5 (T 6)

36/15 (T 6)

36/15 (T 6)

M

36/14 (T 6)

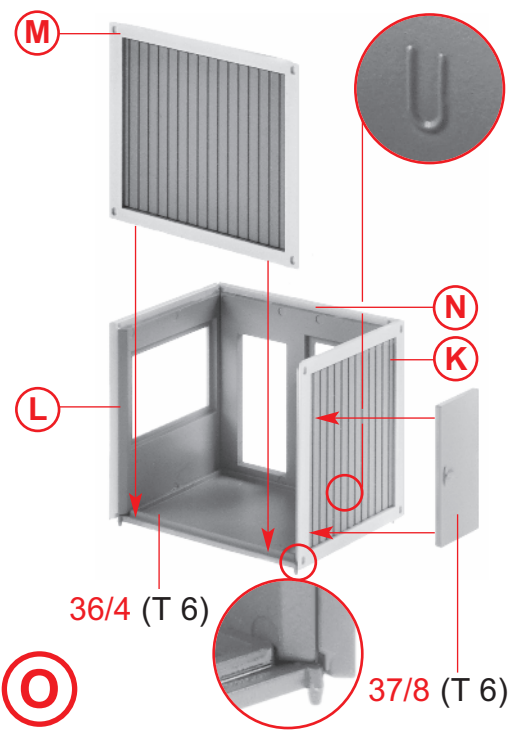
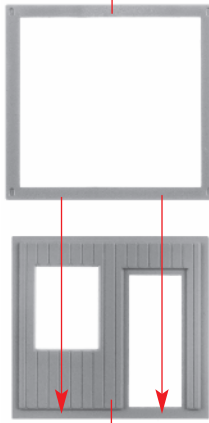
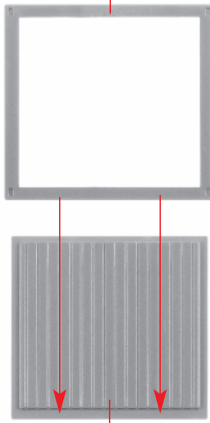
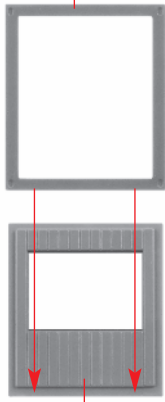
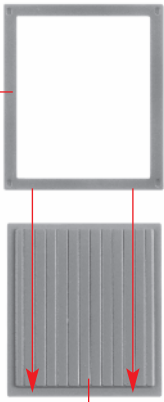

2 x

K 2 x

35/10 (T 6)

L 35/13 (T 6)

M 35/6 (T 6)

N 35/7 (T 6)

O

36/4 (T 6)

37/8 (T 6)

36/6 (T 6)

36/6 (T 6)

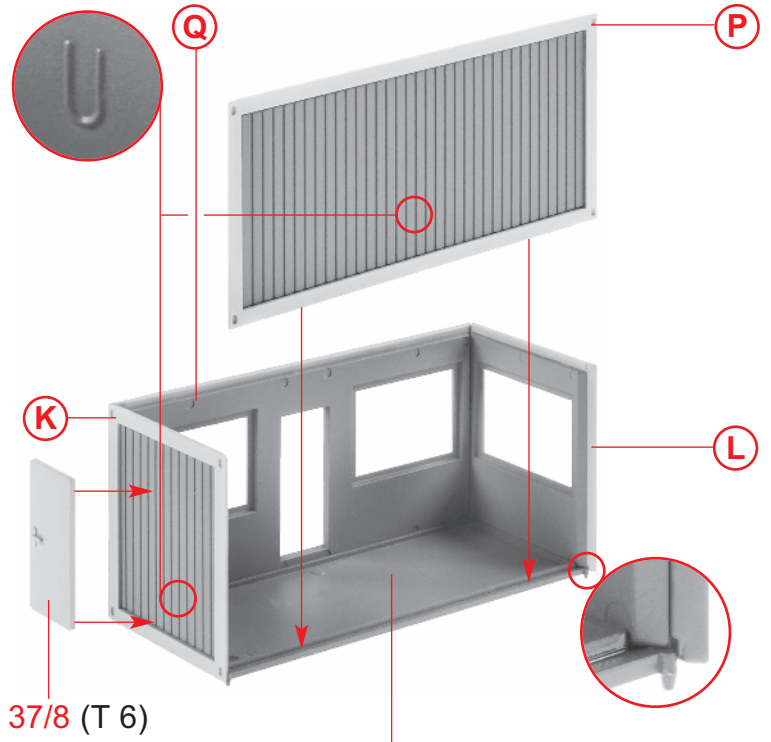
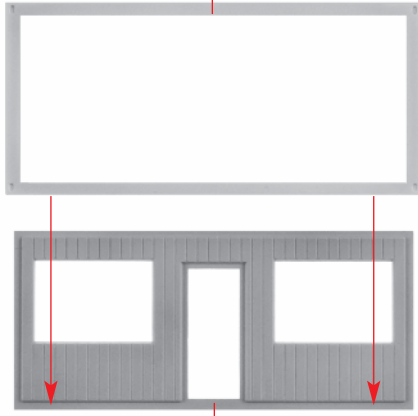
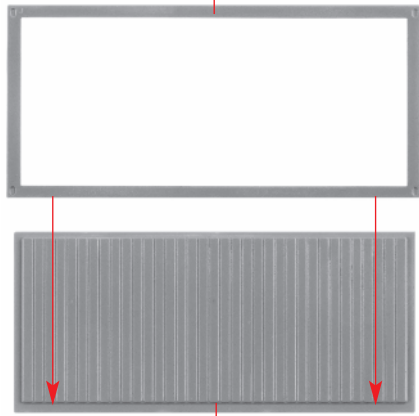

P

35/1 (T 6)

Q

35/4 (T 6)

R

36/2 (T 6)

9/20 (T 4)

9/19 (T 4)

9/20 (T 4)

36/1 (T 6)

36/3 (T 6)

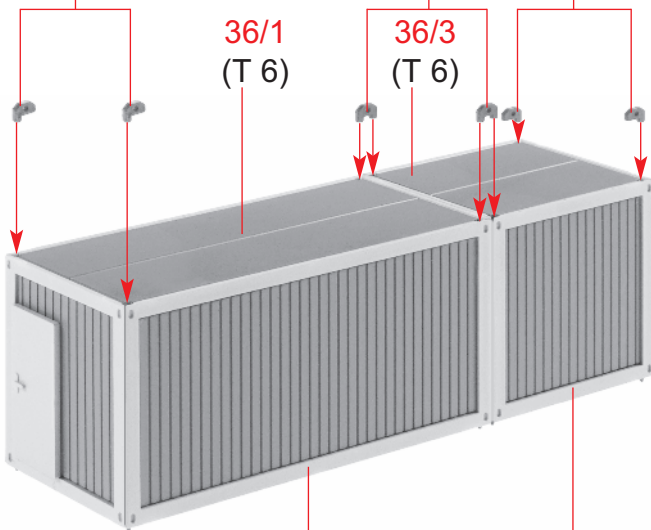

9/17 (T 4)

9/18 (T 4)

9/17 (T 4)

Deco 7

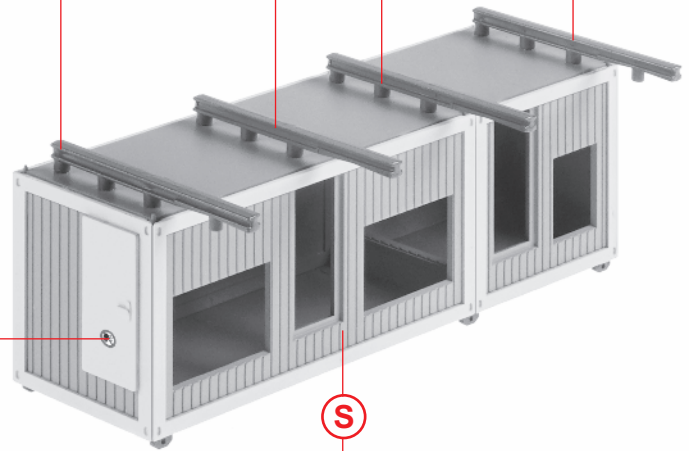

S

R

O

T

S

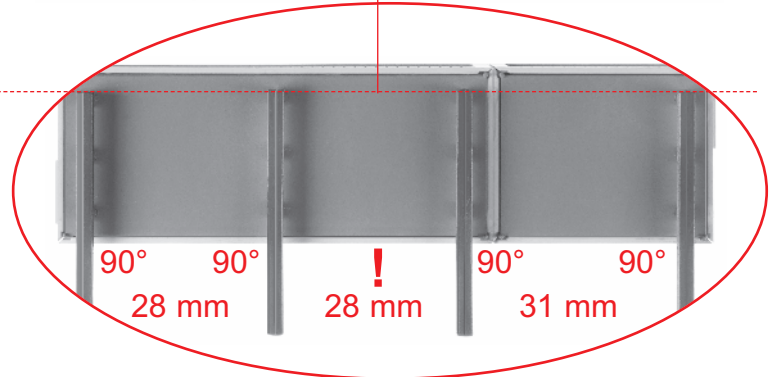

90°
28 mm

90°
28 mm

!
28 mm

90°
31 mm

90°
31 mm

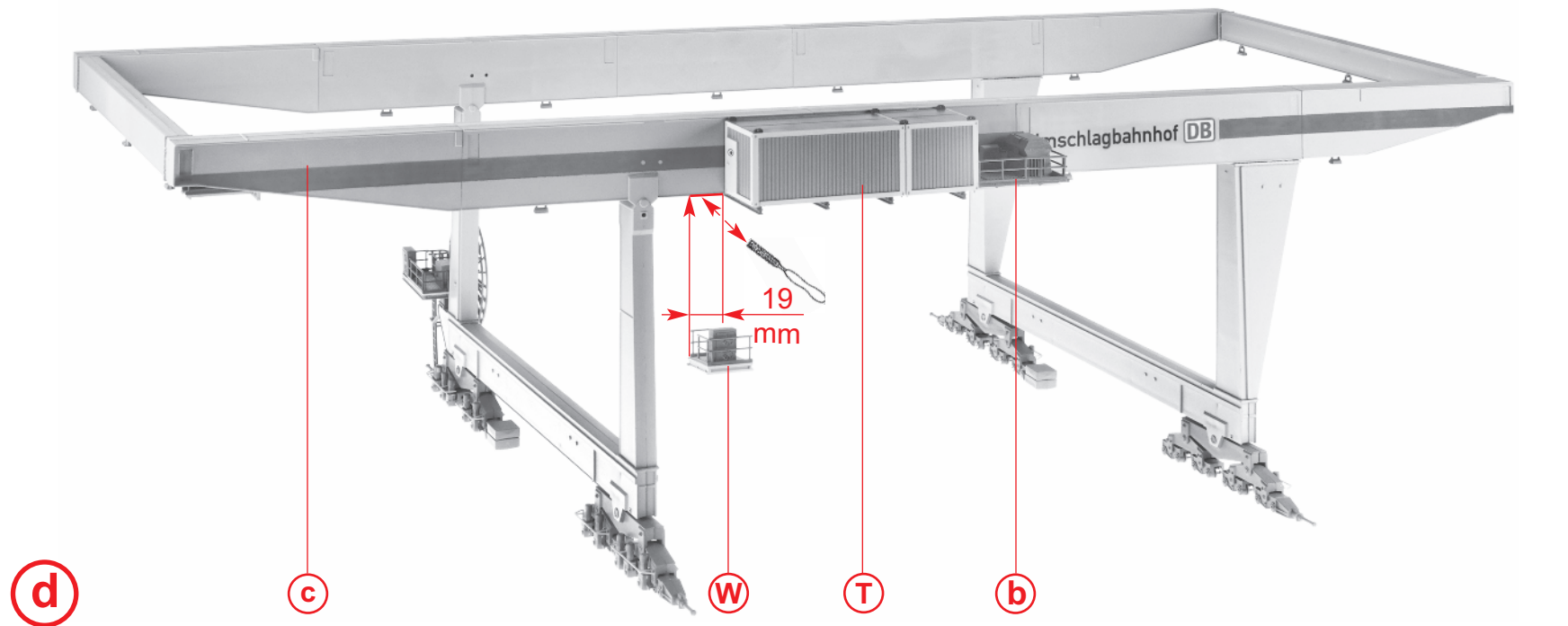
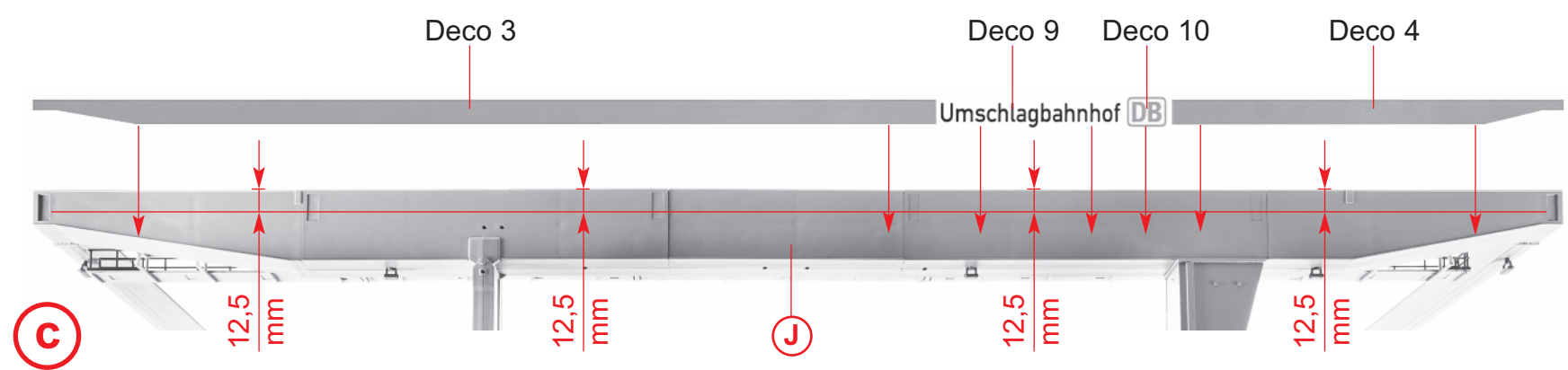
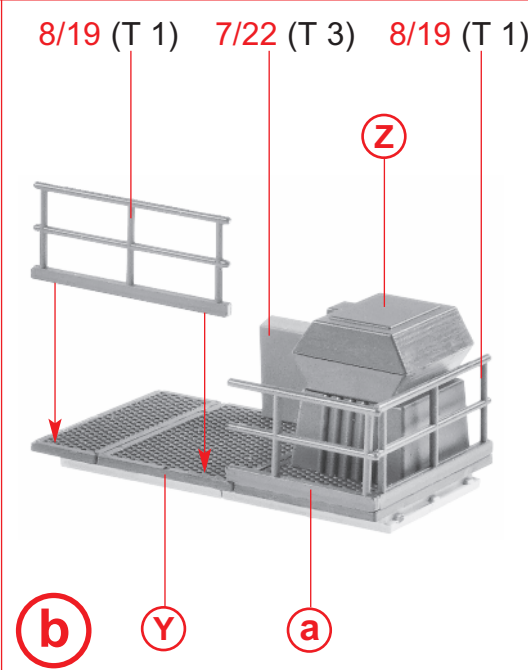
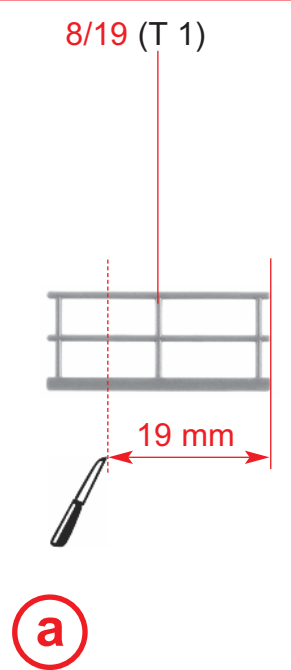
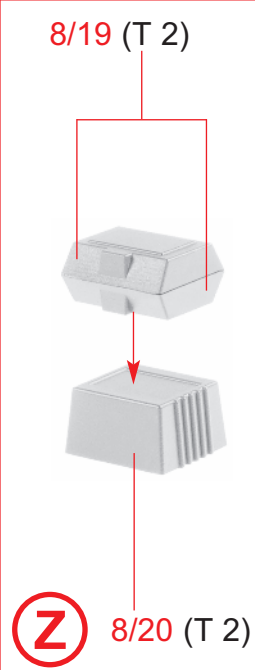
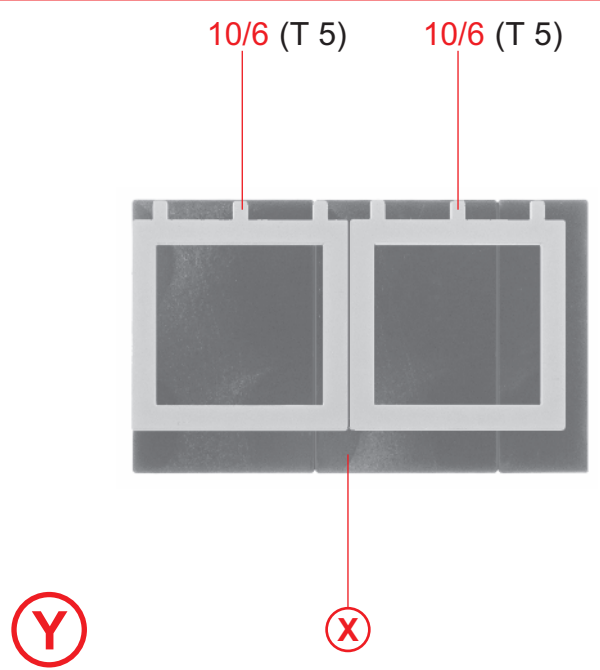
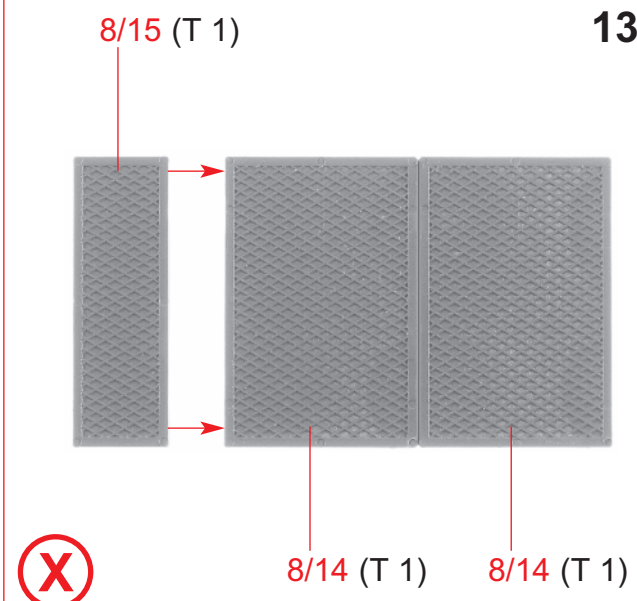
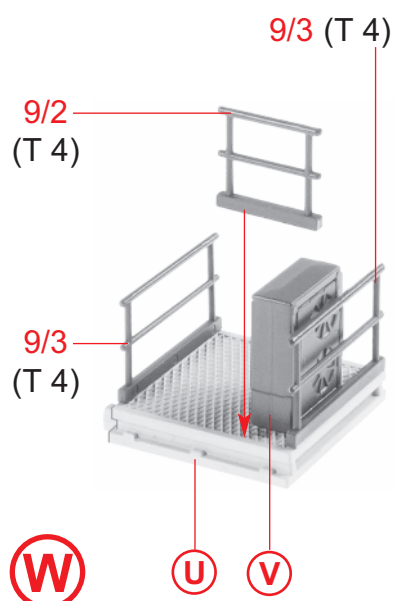
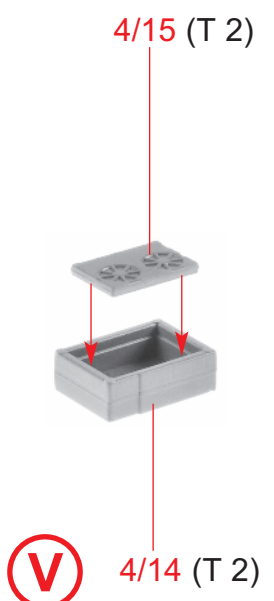
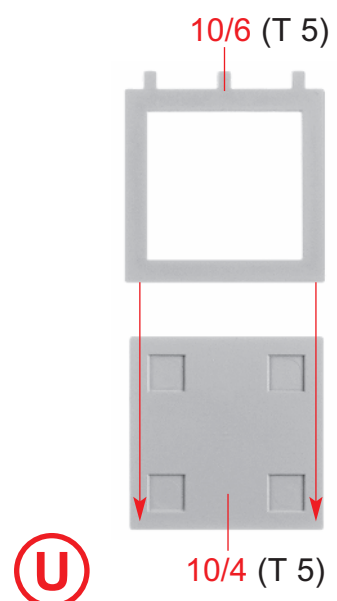

14 Inhalt Tüte 1+2+4+5+6+8
 Contents bag 1+2+4+5+6+8
 Contenu sacnet 1+2+4+5+6+8
 Inhoud zakje 1+2+4+5+6+8

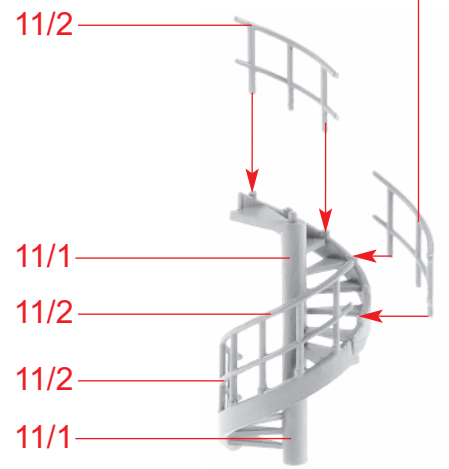

e 3 x

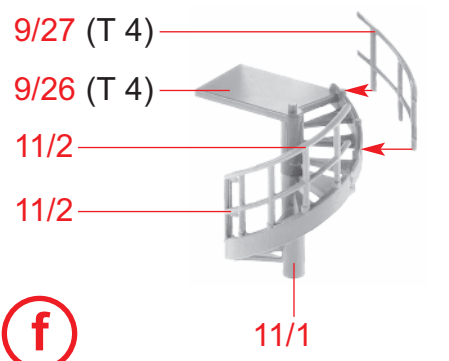

f

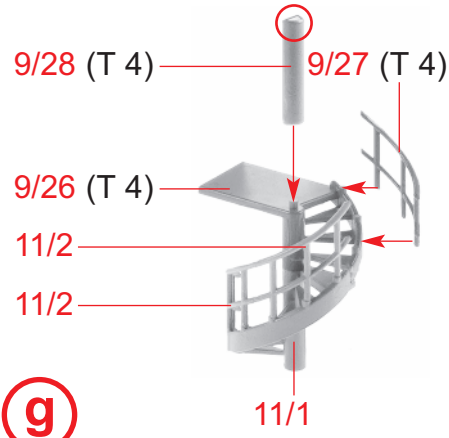

g

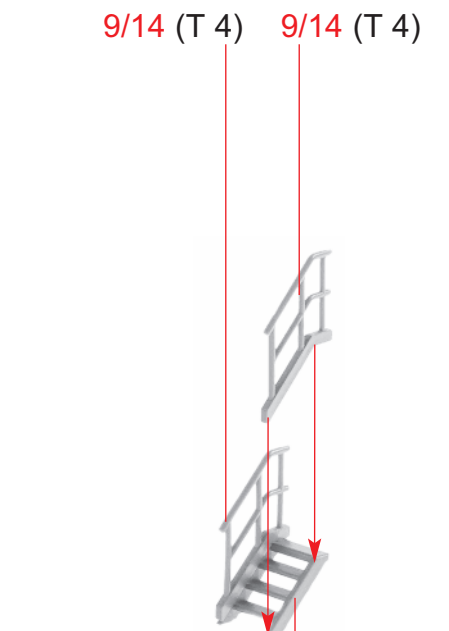

i

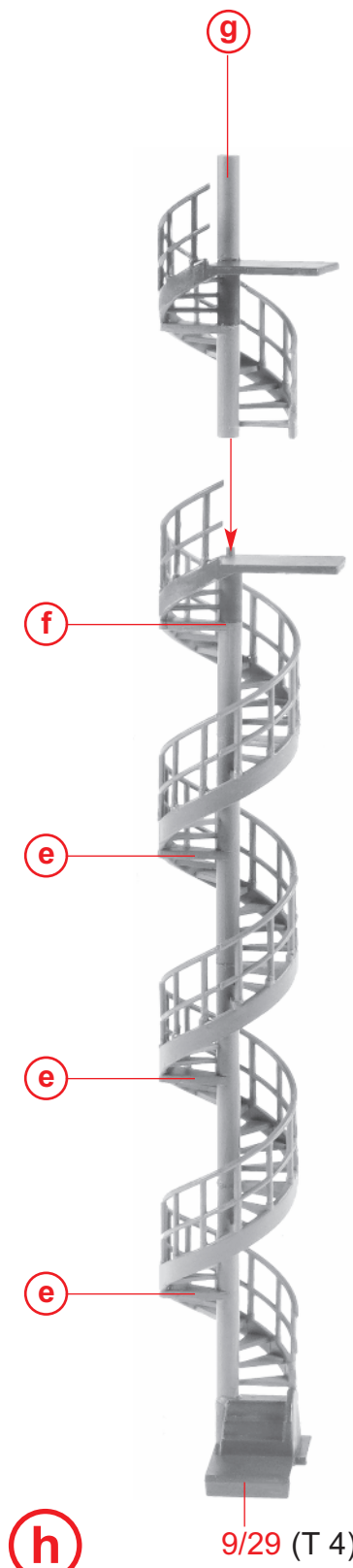

h

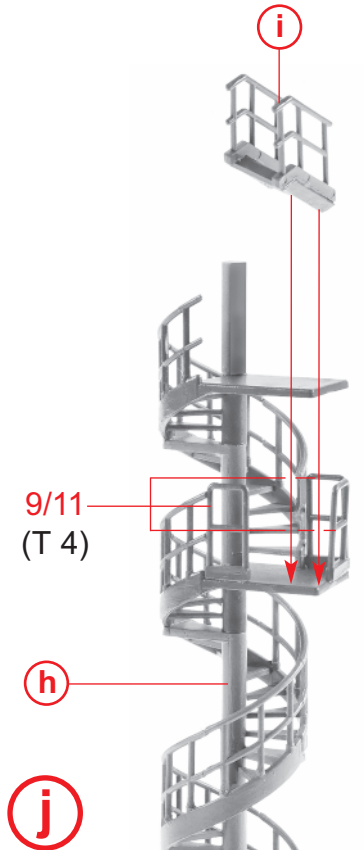

j

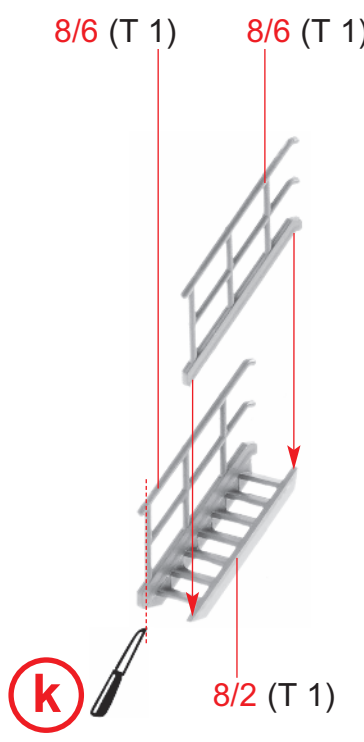

k

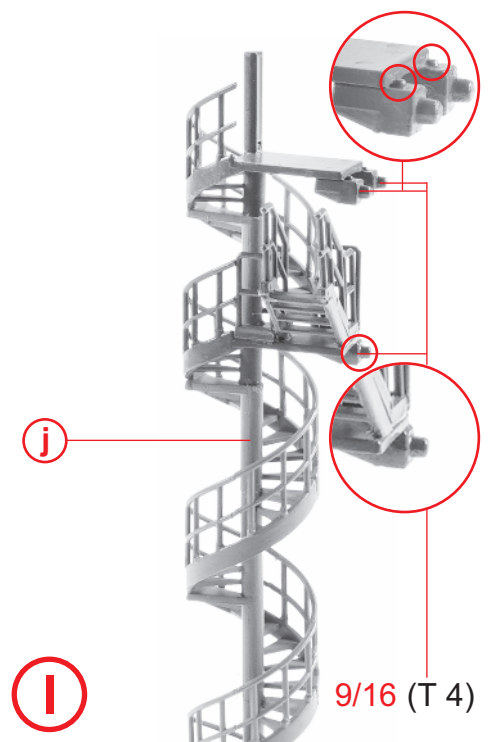

l

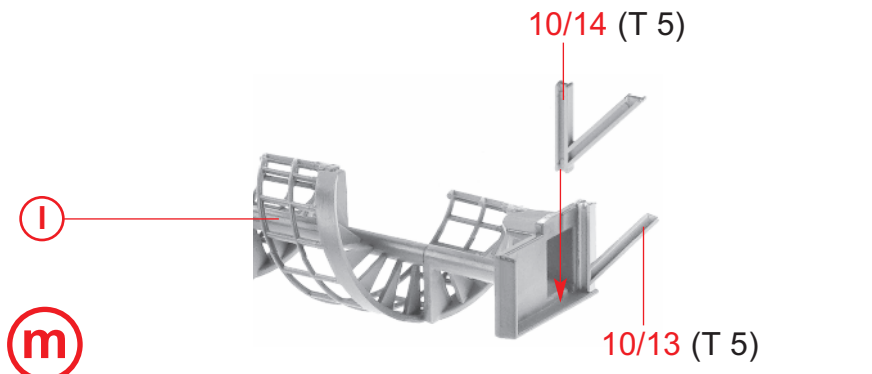

m

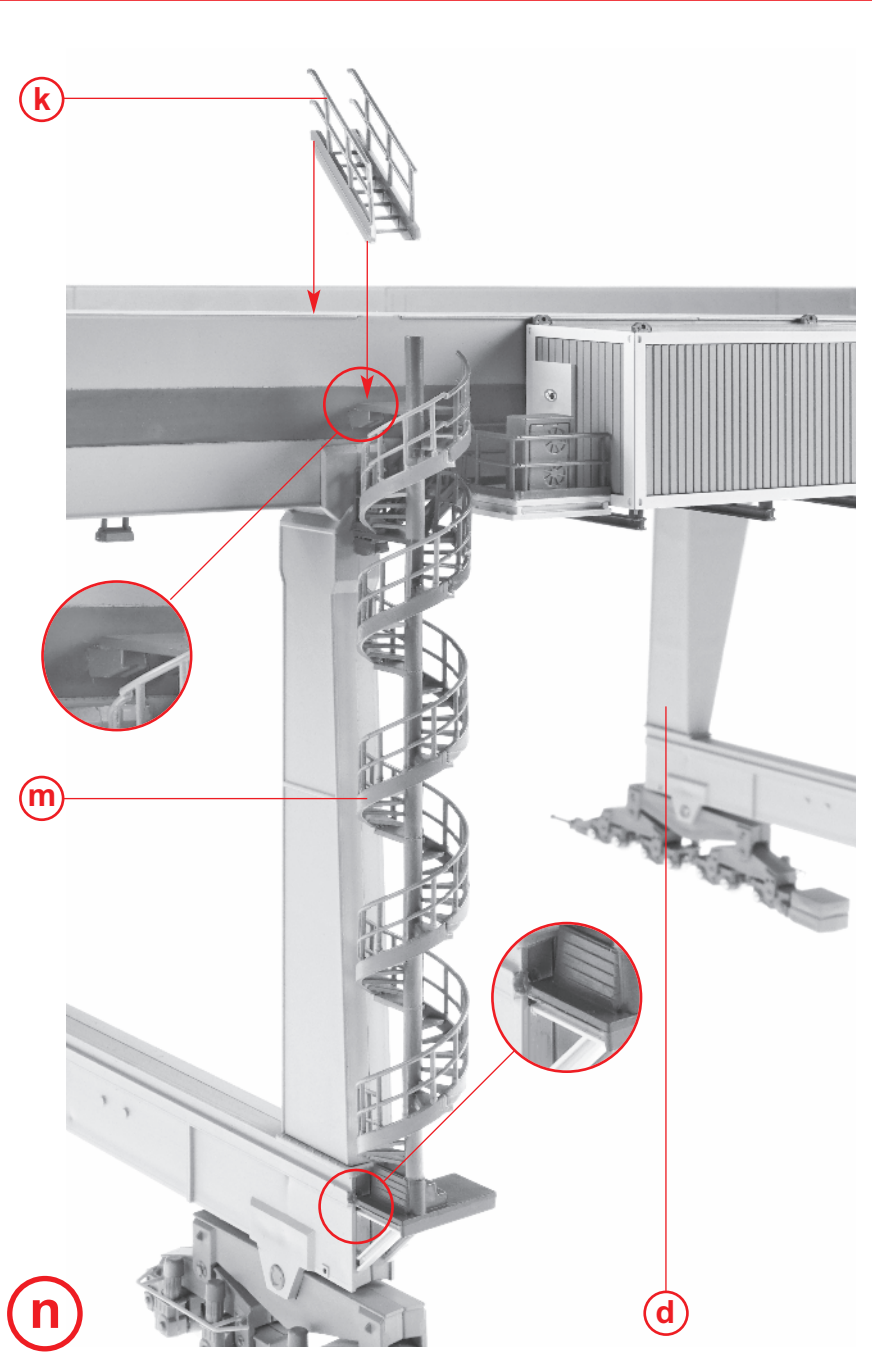

n

d

8/7 (T 1)

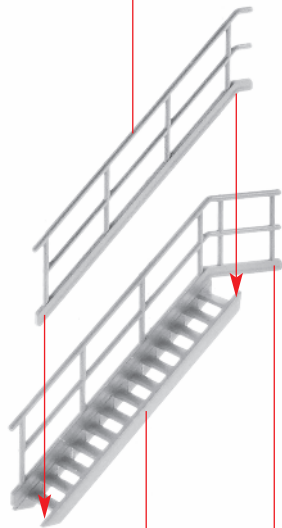

9/15 (T 4)

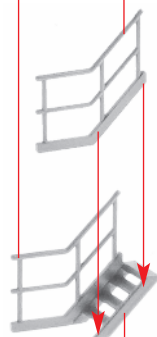

p

o

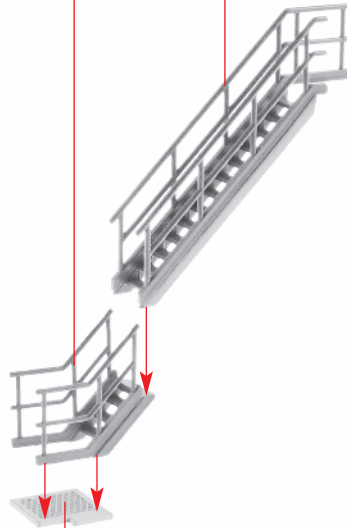

9/1 (T 4)

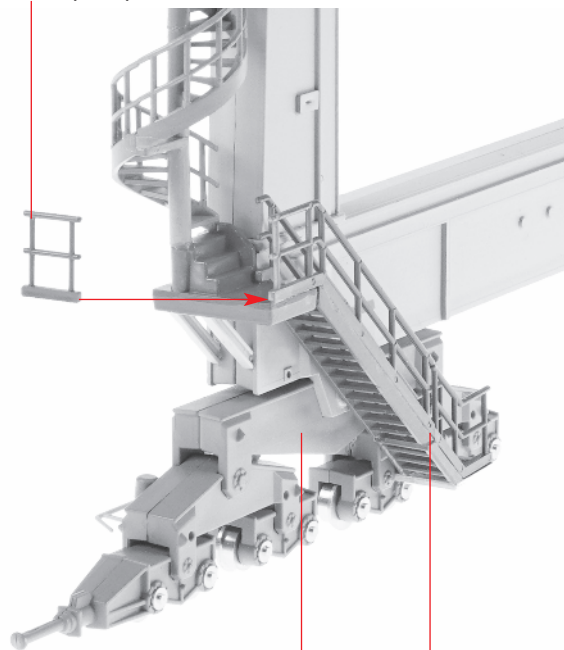

o 8/1 (T 1) 8/5 (T 1)

p 9/13 (T 4)

q 10/5 (T 5)

r **n** **q**

9/11 (T 4) 8/8 (T 1)

8/9 (T 1)

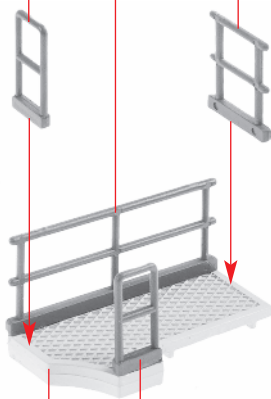

9/11 (T 4)

s 10/11 (T 5)

10/12 (T 5)

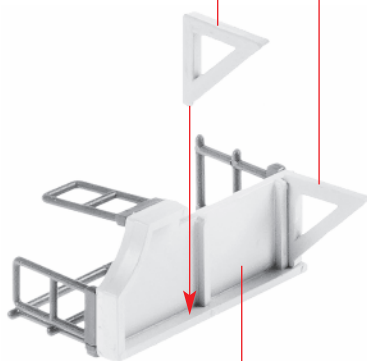

t

s

t

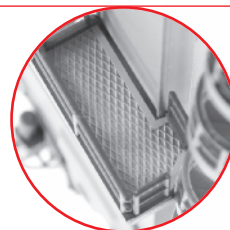

r

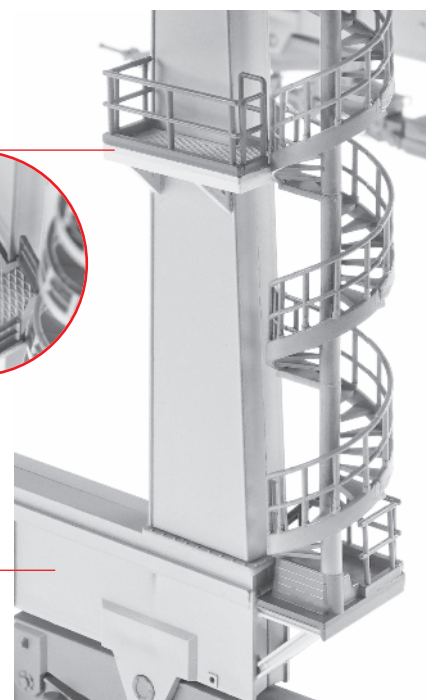

u

4/20 (T 6)

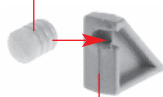

4/18 (T 2)

v 2 x

4/20 (T 6)

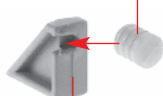

4/19 (T 2)

w 2 x

w

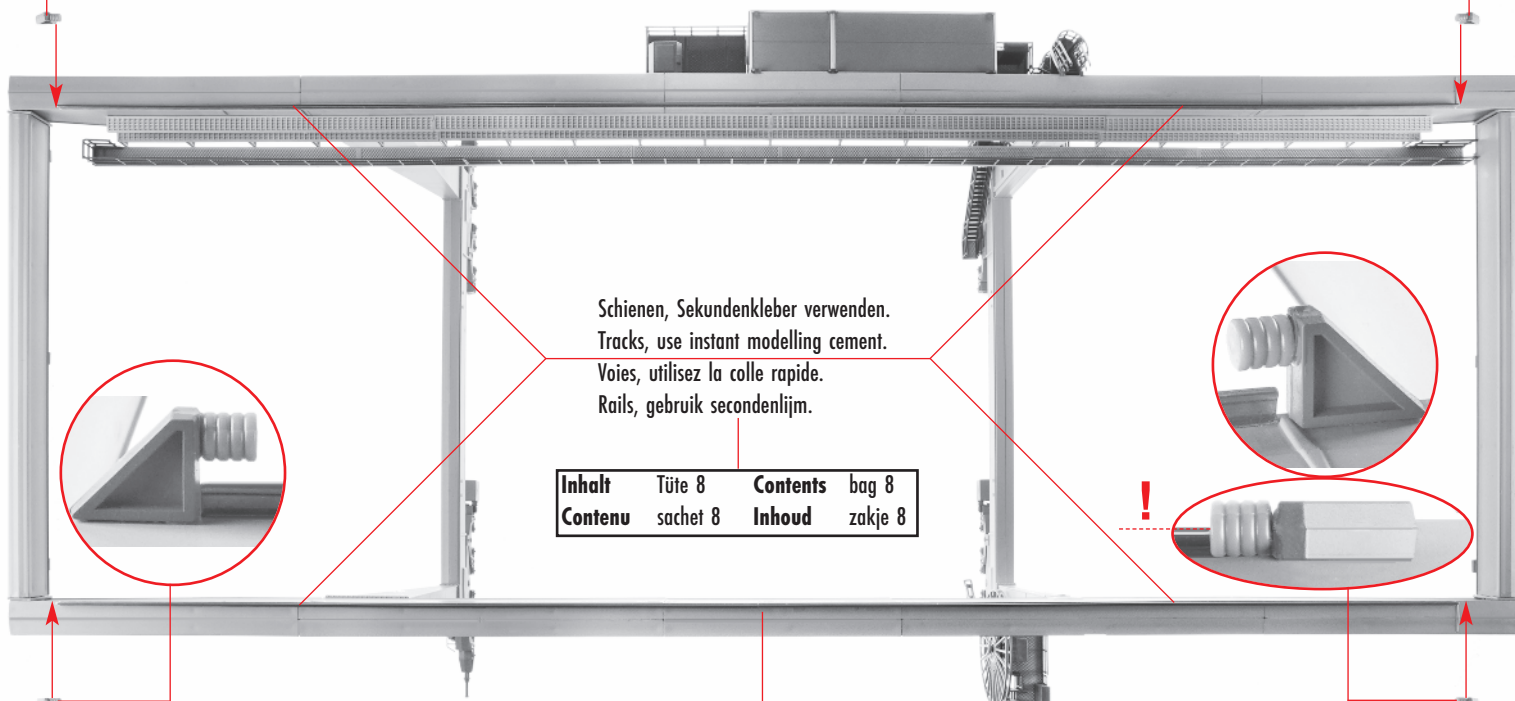

v

x

v

u

w

Schienen, Sekundenkleber verwenden.
Tracks, use instant modelling cement.
Voies, utilisez la colle rapide.
Rails, gebruik secondenlijm.

Inhalt	Tüte 8	Contents	bag 8
Contenu	sachet 8	Inhoud	zakje 8

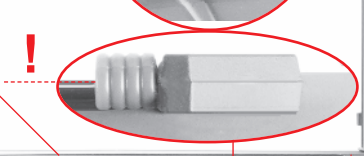

Inhalt	Tüte 1+4
Contents	bag 1+4
Contenu	sachet 1+4
Inhoud	zakje 1+4

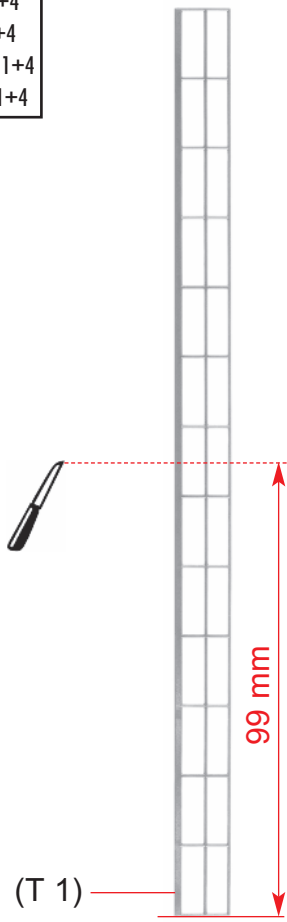

A

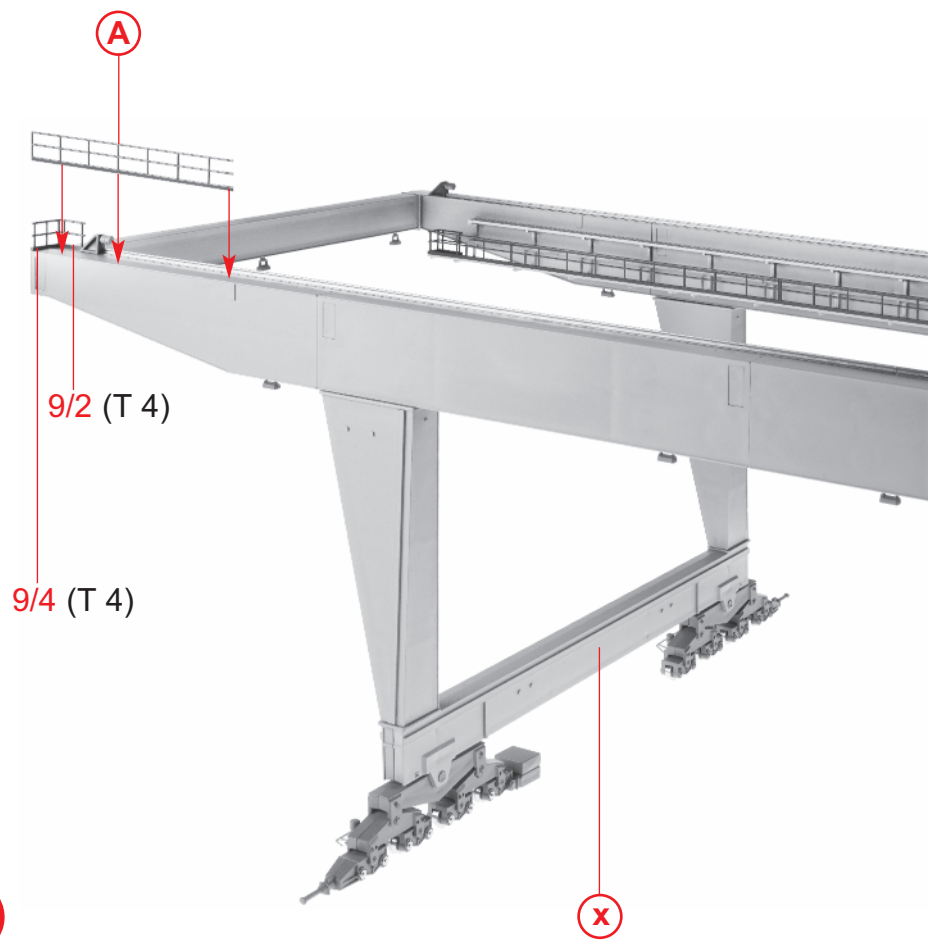

B

x

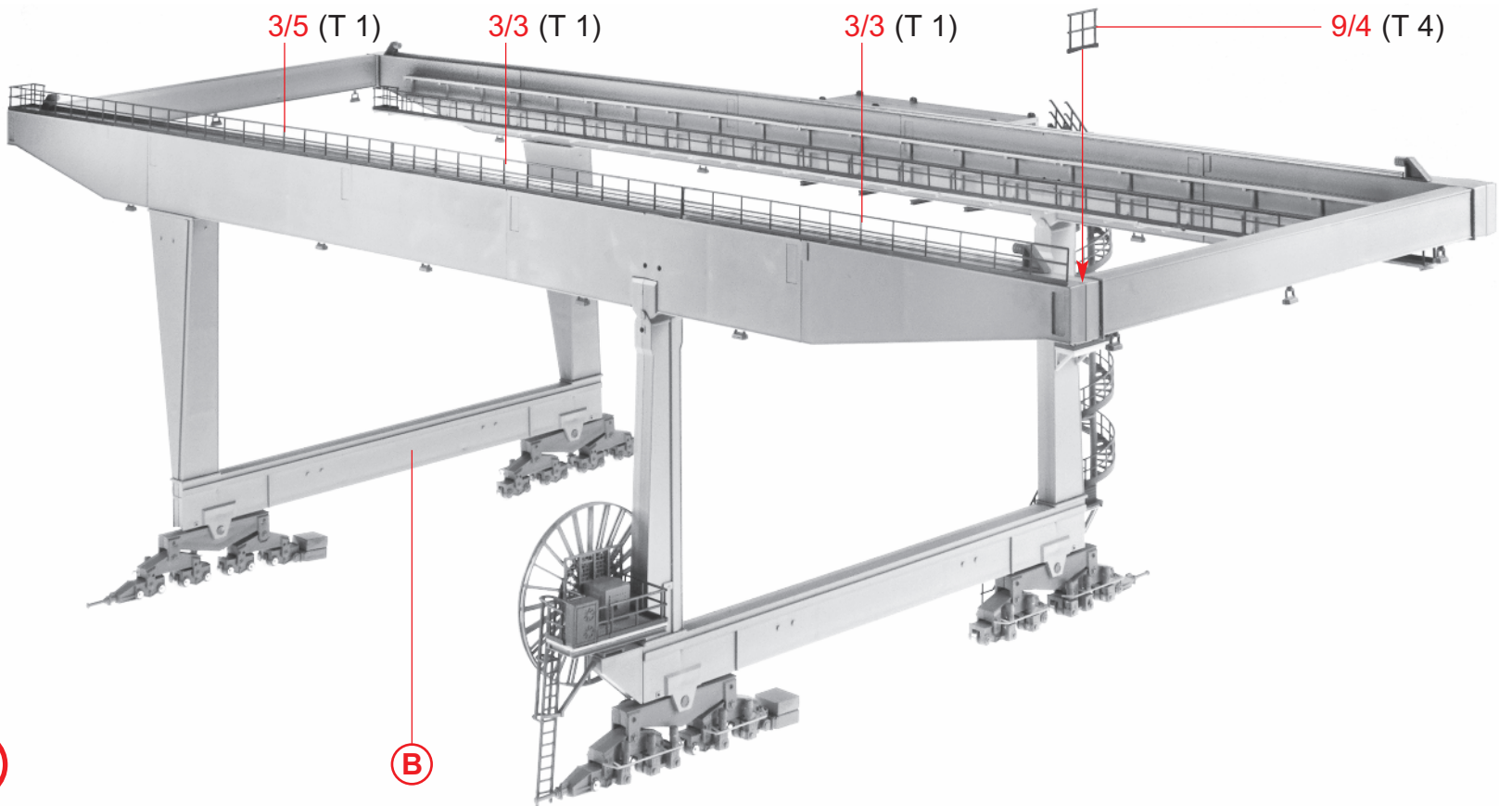

C

B

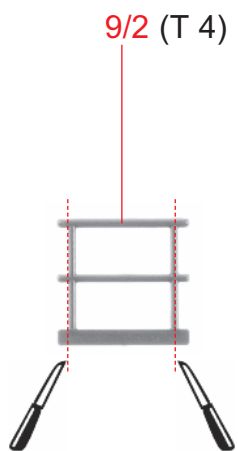

D

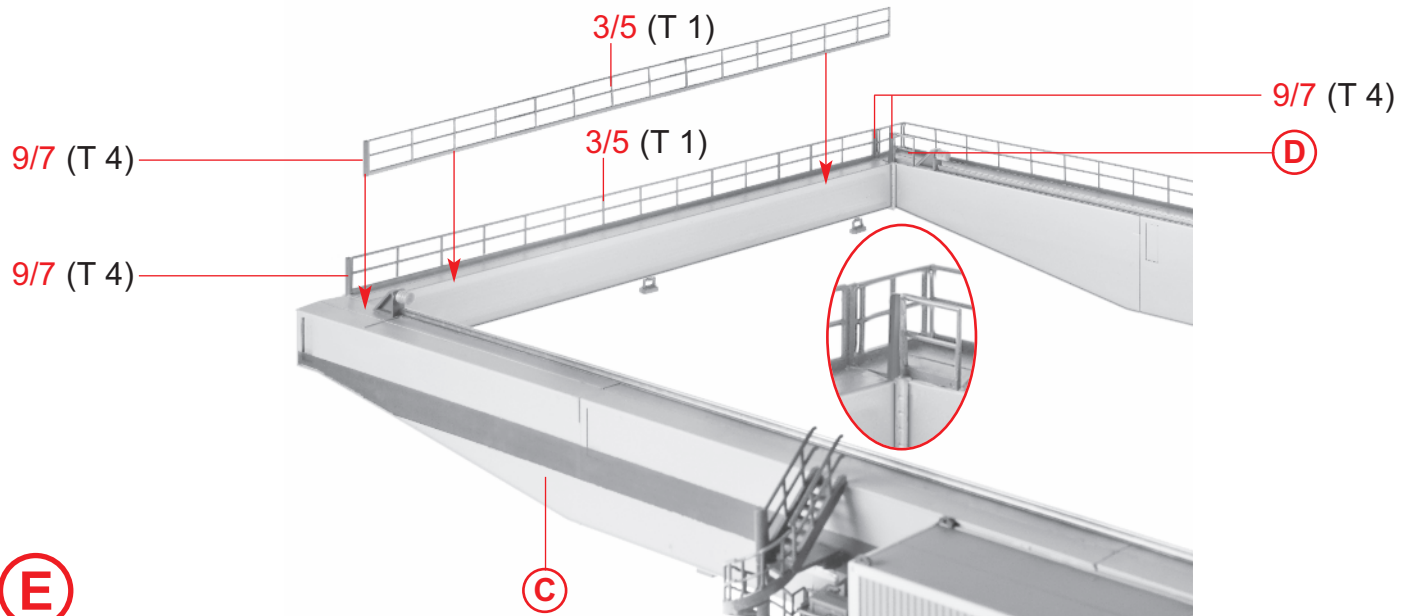

E

C

D

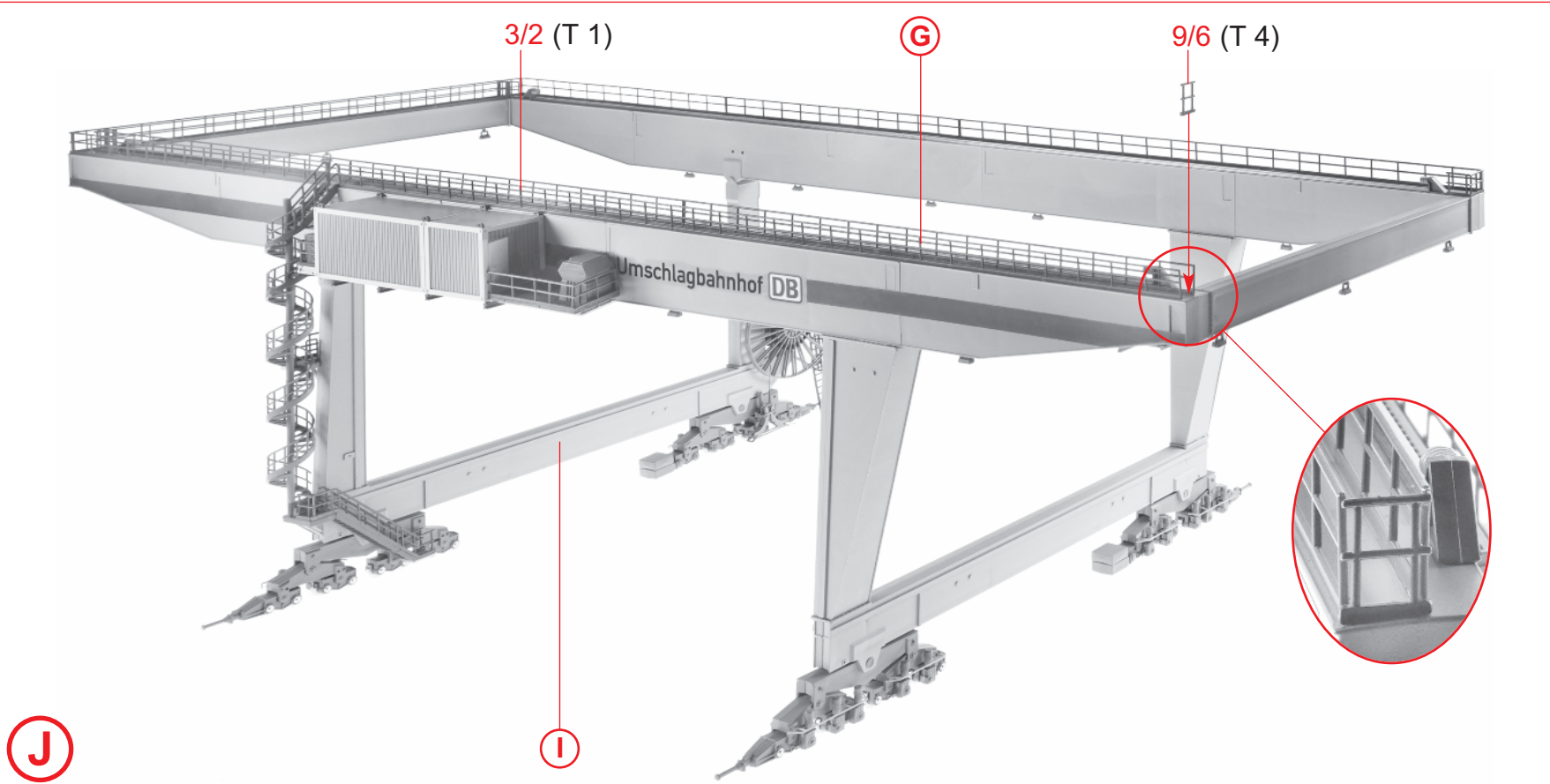
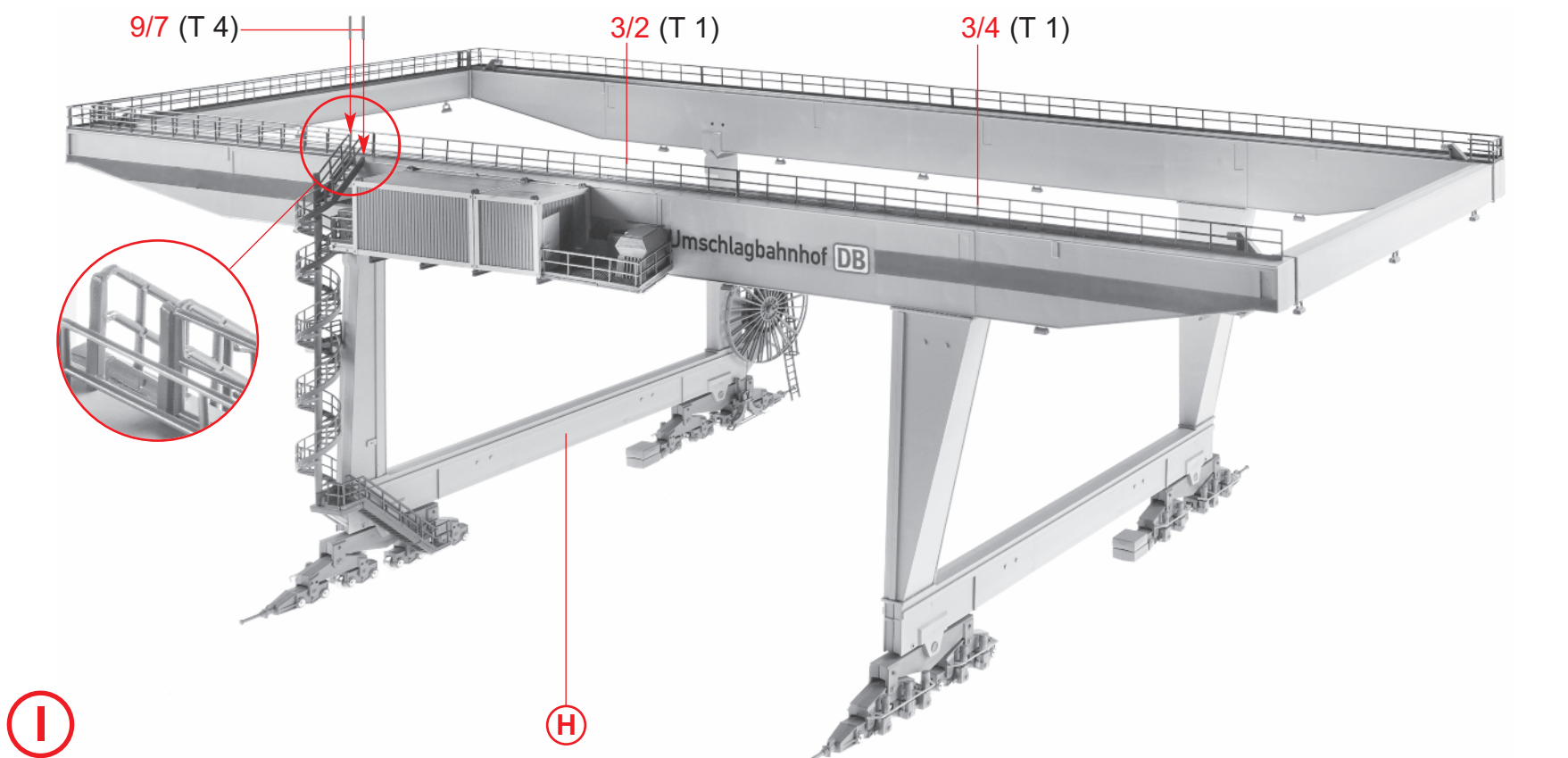
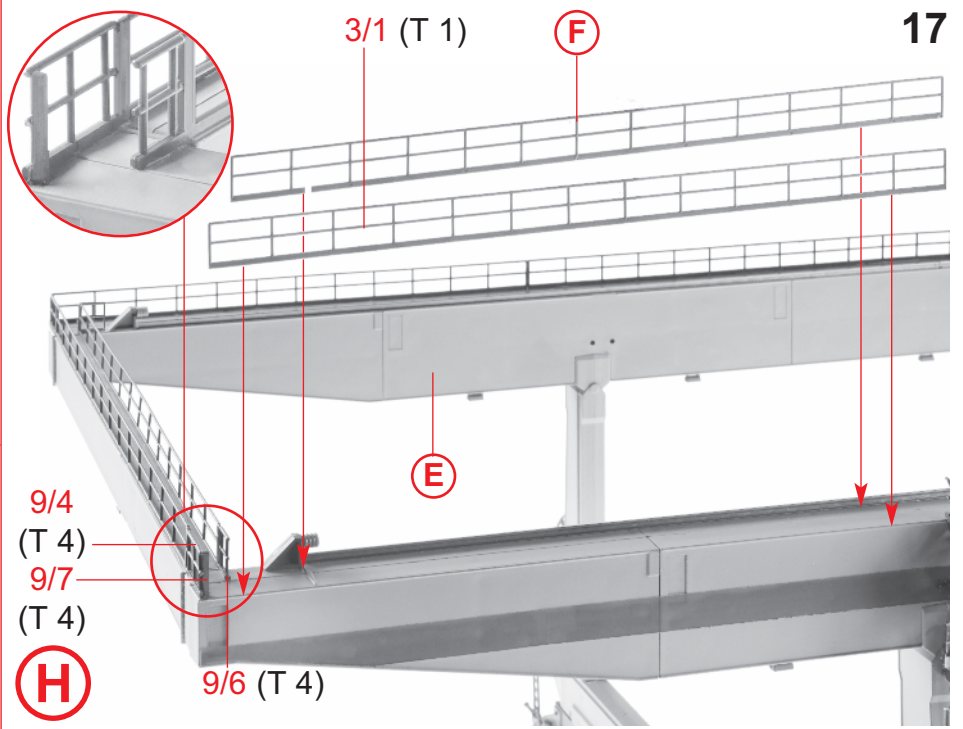
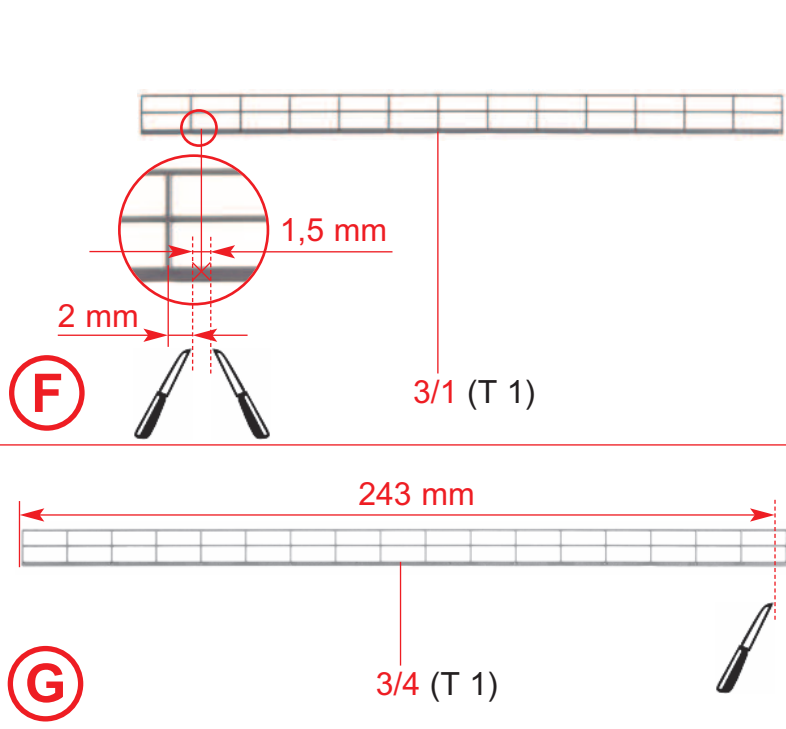

18

Inhalt	Tüte 1+2+3+4+5+6+7
Contents	bag 1+2+3+4+5+6+7
Contenu	sachet 1+2+3+4+5+6+7
Inhoud	zakje 1+2+3+4+5+6+7

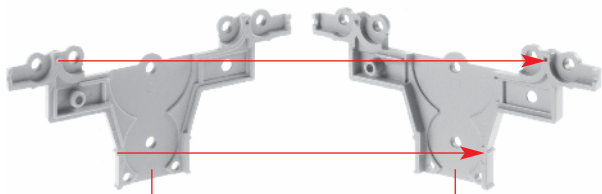

K 2 x 7/7 (T 3)

Nur eindrücken, nicht kleben.
Press in only, do not glue.
Ne pas enfoncer, ne pas coller.
Alleen indrukken, niet lijmen.

Inhalt	Tüte 7	Contents	bag 7
Contenu	sachet 7	Inhoud	zakje 7

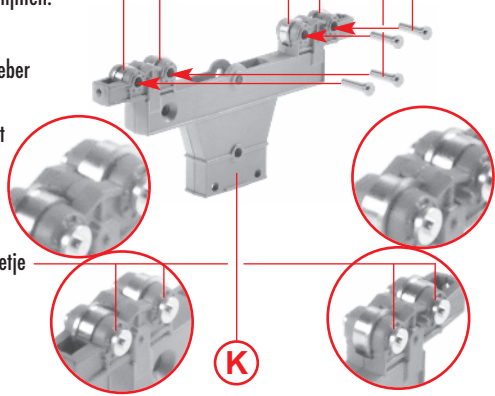

L 2 x

Nur wenig Sekundenkleber verwenden!
Use only a little instant modelling cement!
Utilisez seulement un peu de colle rapide!
Gebruik slechts een beetje secondenlijm!

K

M 2 x

10/3 (T 5)

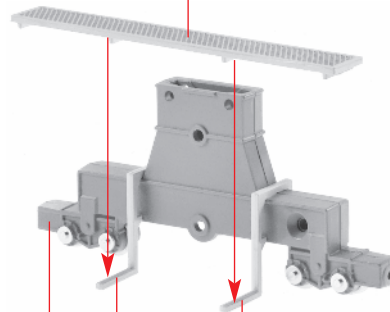

L 10/8 (T 5)

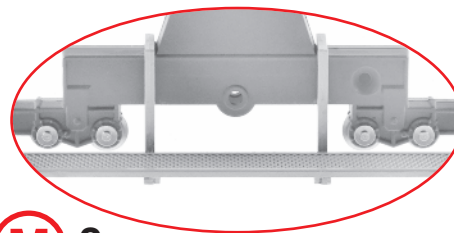

Nur wenig Sekundenkleber verwenden!
Use only a little instant modelling cement!
Utilisez seulement un peu de colle rapide!
Gebruik slechts een beetje secondenlijm!

8/19 (T 1)

4/20 (T 6)

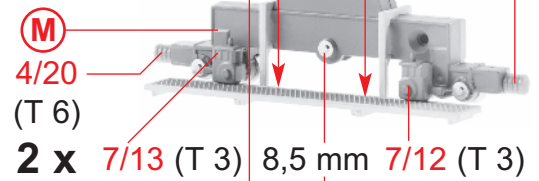

Inhalt	Tüte 7	Contents	bag 7
Contenu	sachet 7	Inhoud	zakje 7

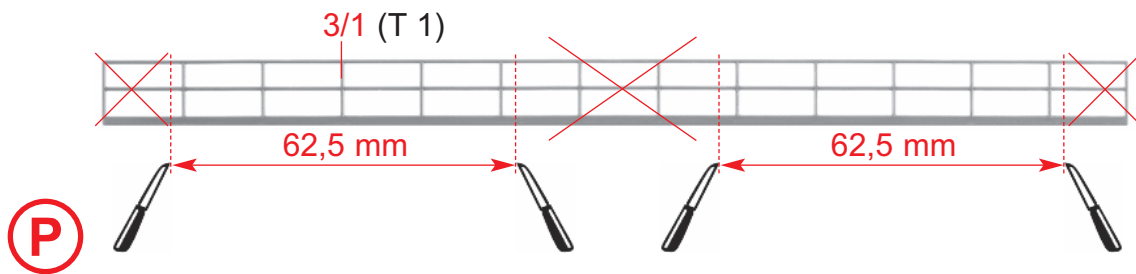
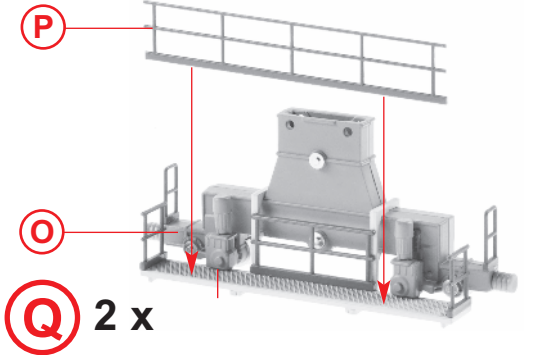
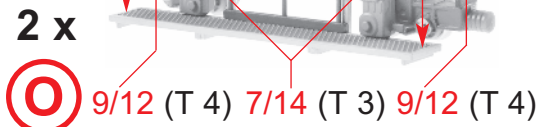

P

Q 2 x

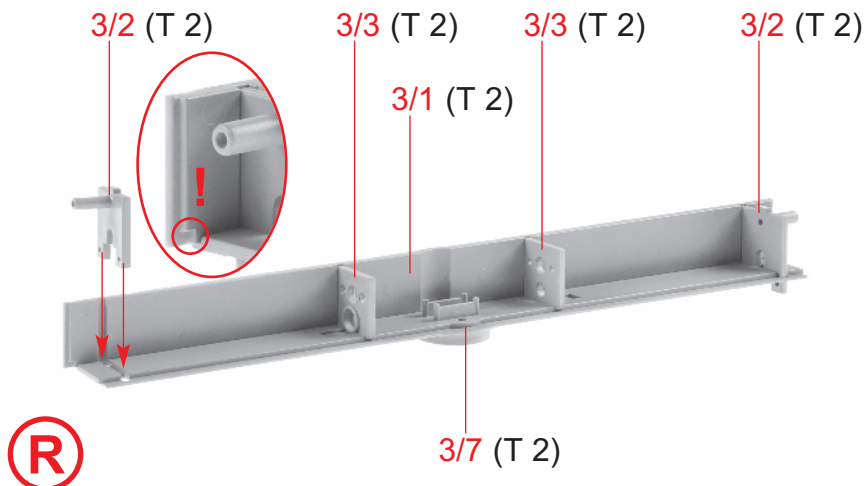

R

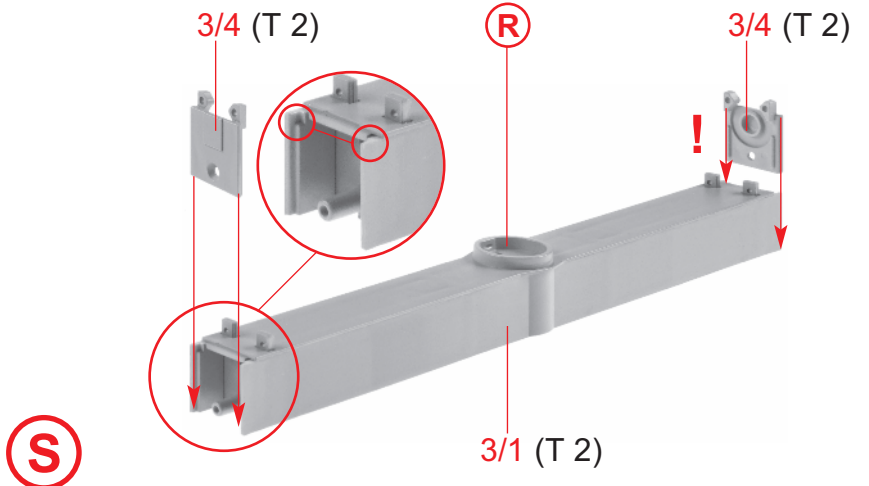

S

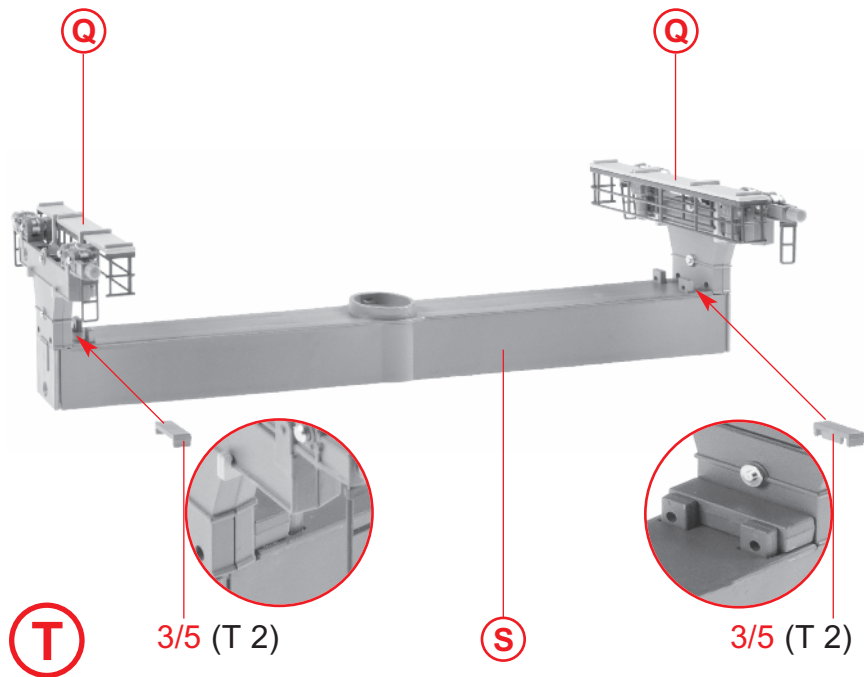

T

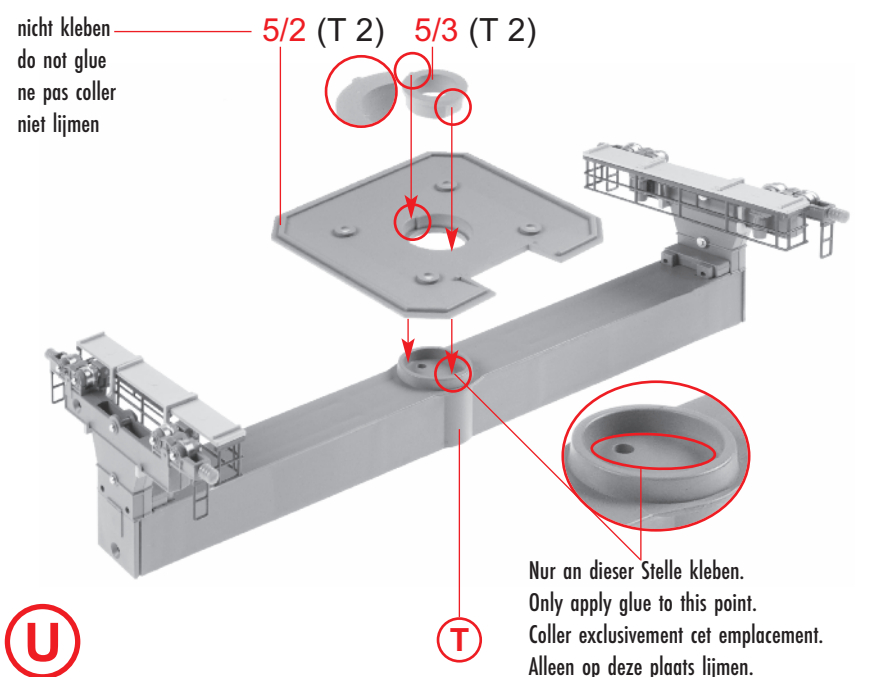

U

nicht kleben
do not glue
ne pas coller
niet lijmen

Nur an dieser Stelle kleben.
Only apply glue to this point.
Coller exclusivement cet emplacement.
Alleen op deze plaats lijmen.

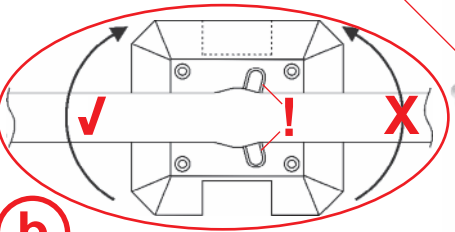
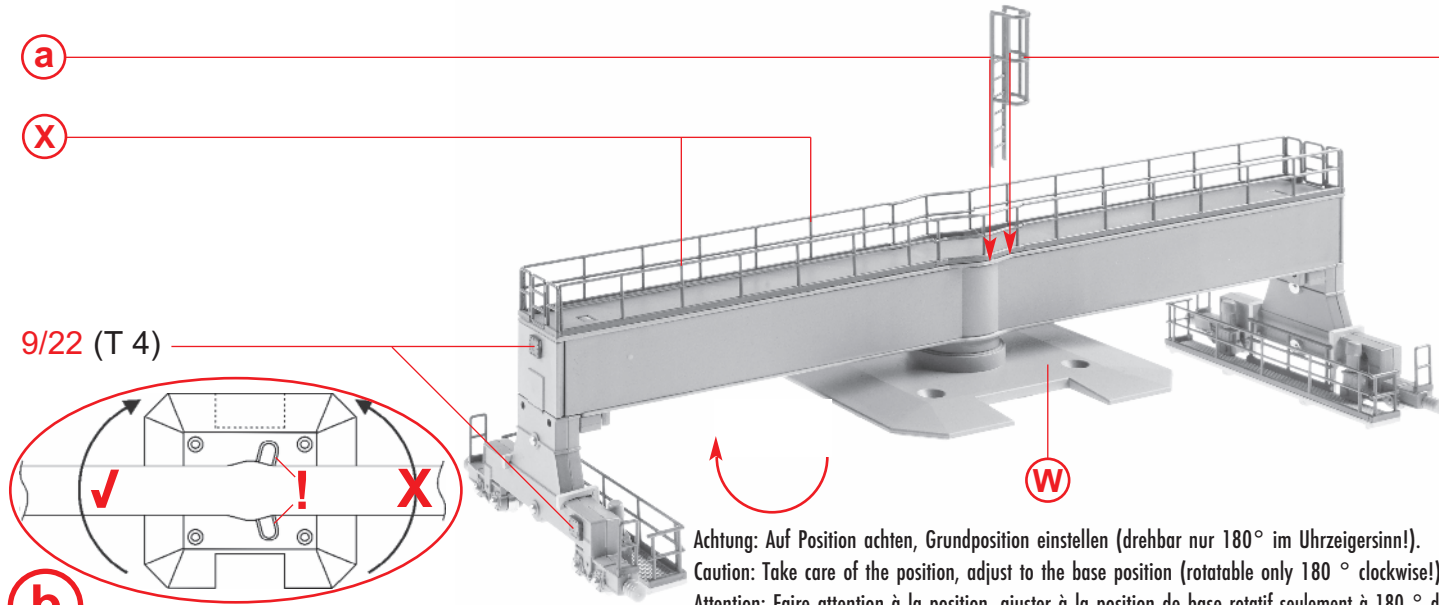
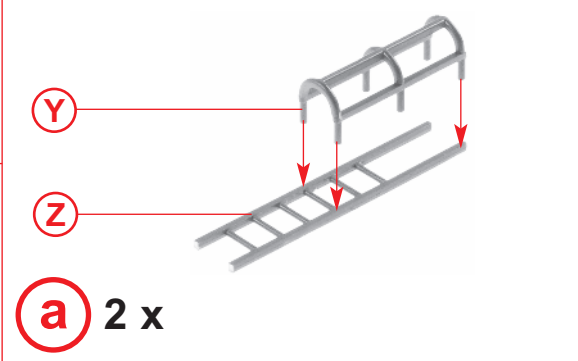
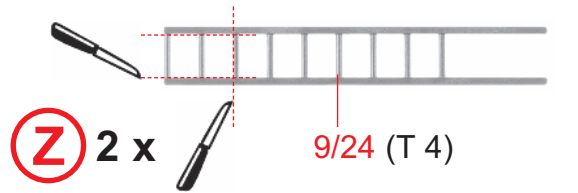
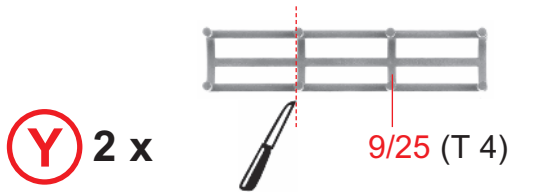
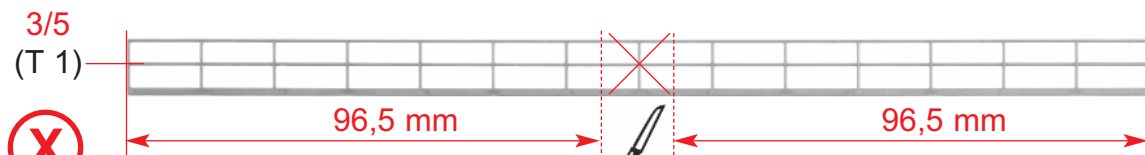
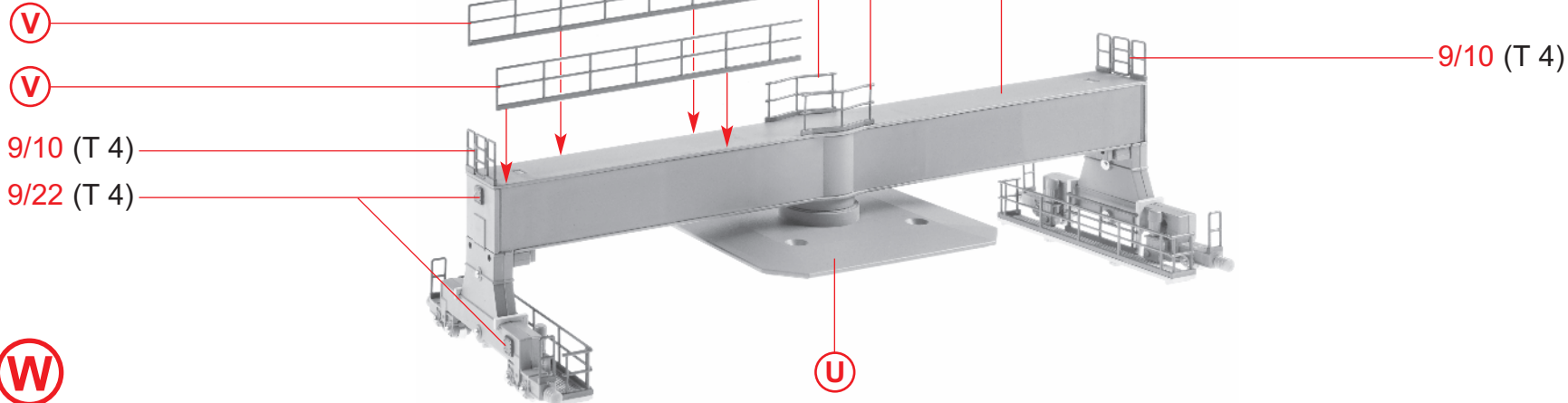
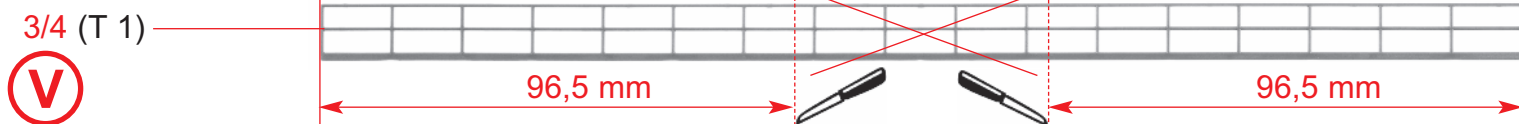

Achtung: Auf Position achten, Grundposition einstellen (drehbar nur 180° im Uhrzeigersinn!).
 Caution: Take care of the position, adjust to the base position (rotatable only 180° clockwise!).
 Attention: Faire attention à la position, ajuster à la position de base rotatif seulement à 180° dans le sens des aiguilles d'une montre!.
 Let op: op positie letten, uitgangspositie instellen (slechts 180° met de klok mee roteerbaar!).

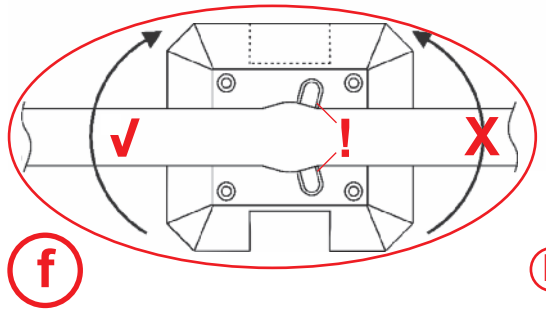
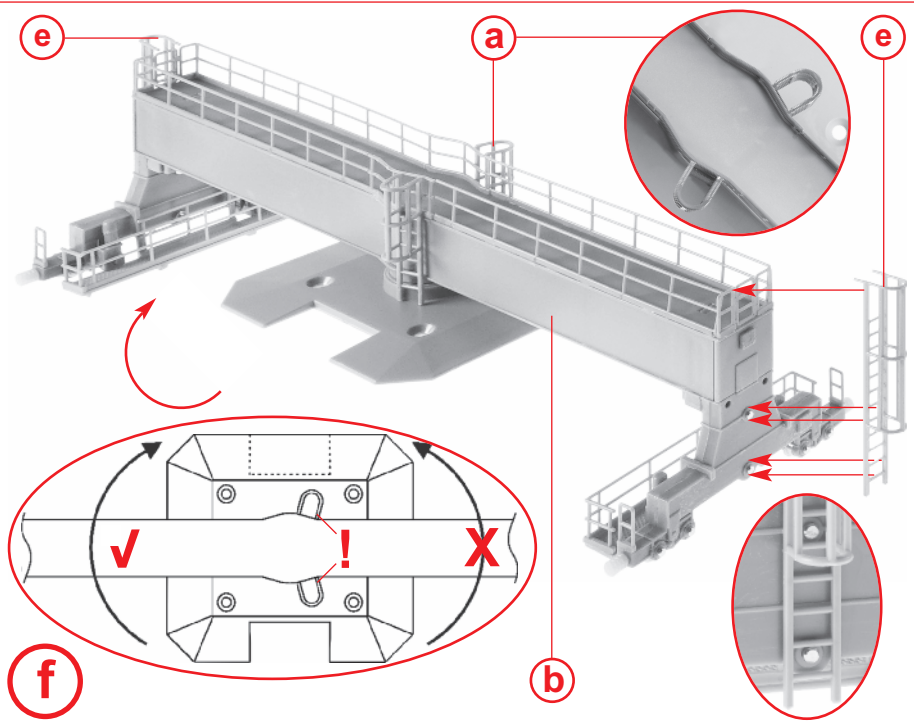
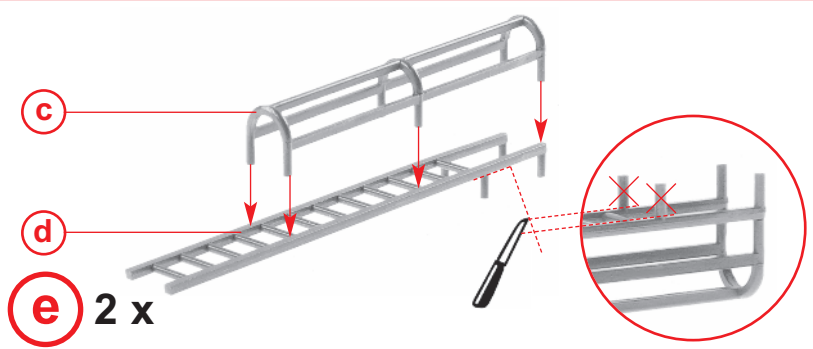
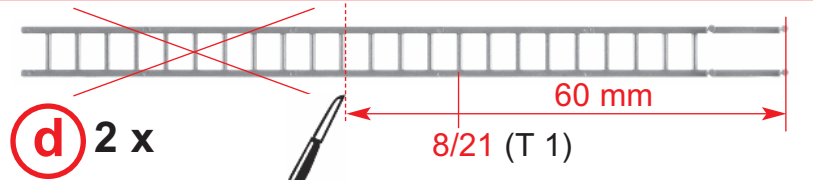
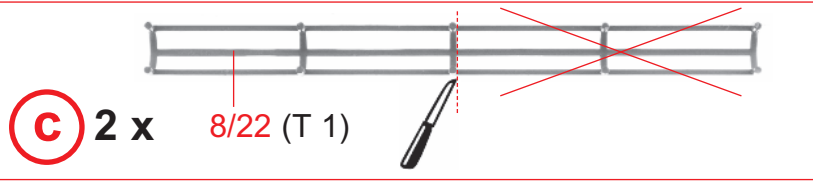

20

Inhalt Tüte 2+3+4+7
Contents bag 2+3+4+7
Contenu sachet 2+3+4+7
Inhoud zakje 2+3+4+7

Lasercut-Kleber verwenden.
 Use Lasercut glue.
 Utilisez la colle Lasercut.
 Gebruik Lasercutlijm.

Montagehilfe
 Mounting aid
 Aide de montage
 Montagehulp

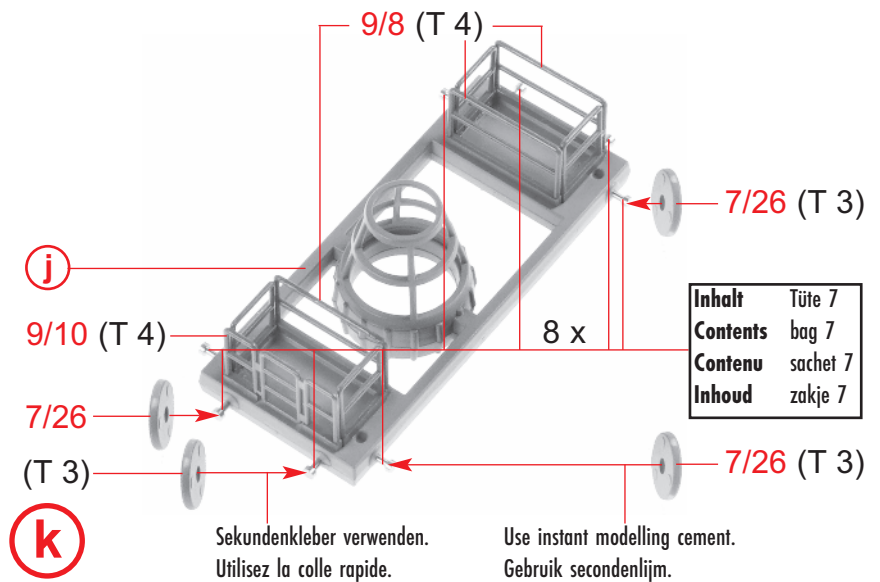
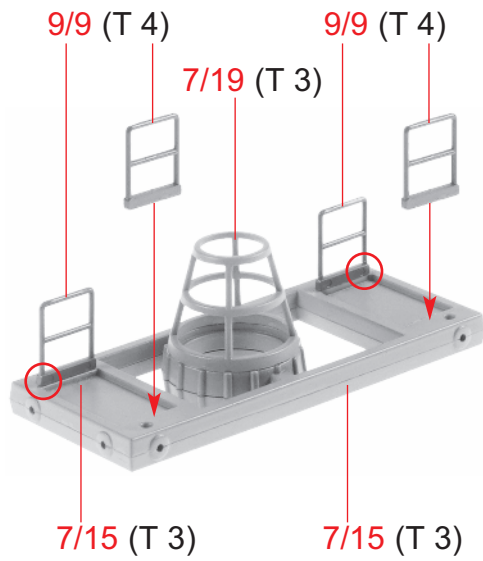
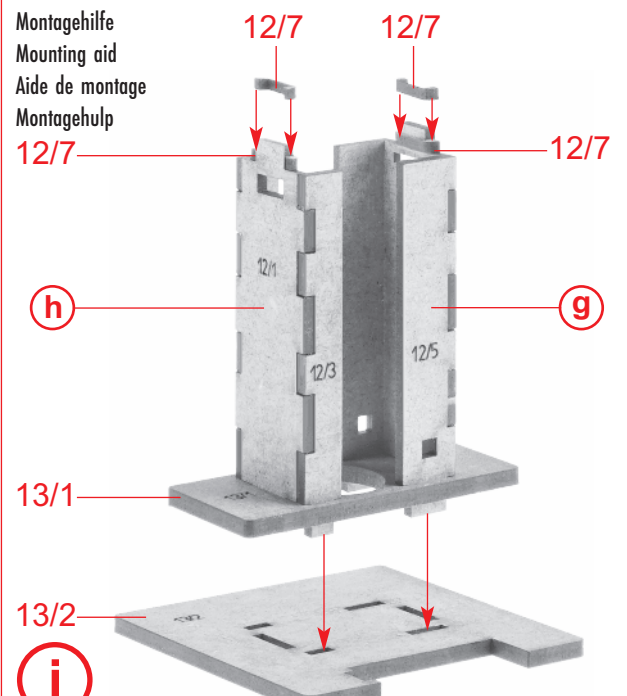
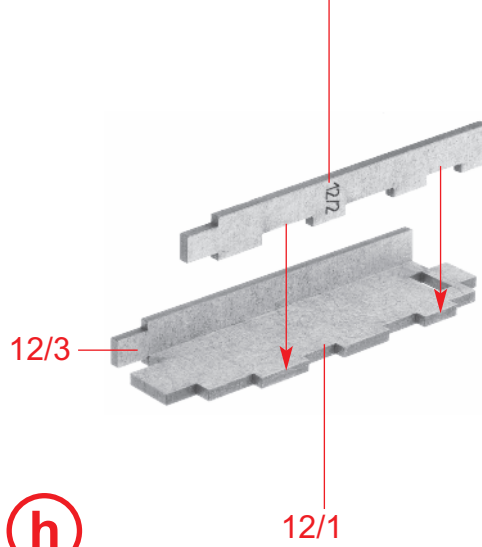
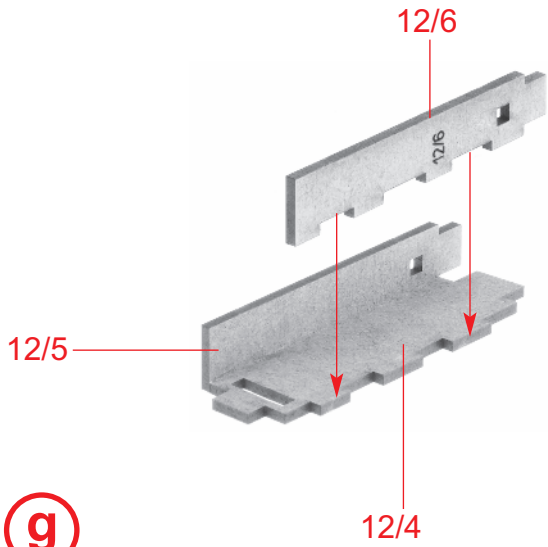

Inhalt Tüte 7
Contents bag 7
Contenu sachet 7
Inhoud zakje 7

Sekundenkleber verwenden.
 Utilisez la colle rapide.
 Use instant modelling cement.
 Gebruik secondenlijm.



Faden
 Cord
 Aiguillée
 Garen

4 x 350 mm

Faden 3 x verknoten und den Knoten mit Sekundenkleber fixieren!
 Knot the thread (3 times) and fix the thread with instant cement!
 Nouer le fil (3 x) et renforcer le noeud avec une goutte de colle rapide!
 Garen vastknopen (3 x) en de knoop met secondenlijm fixeren!

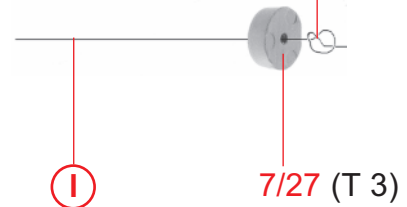

l

m 4 x

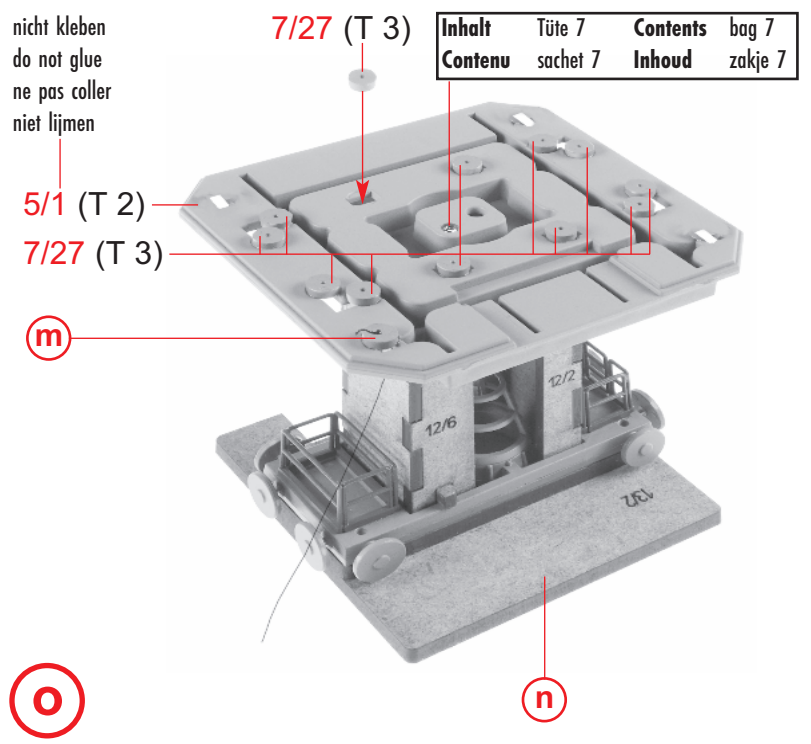
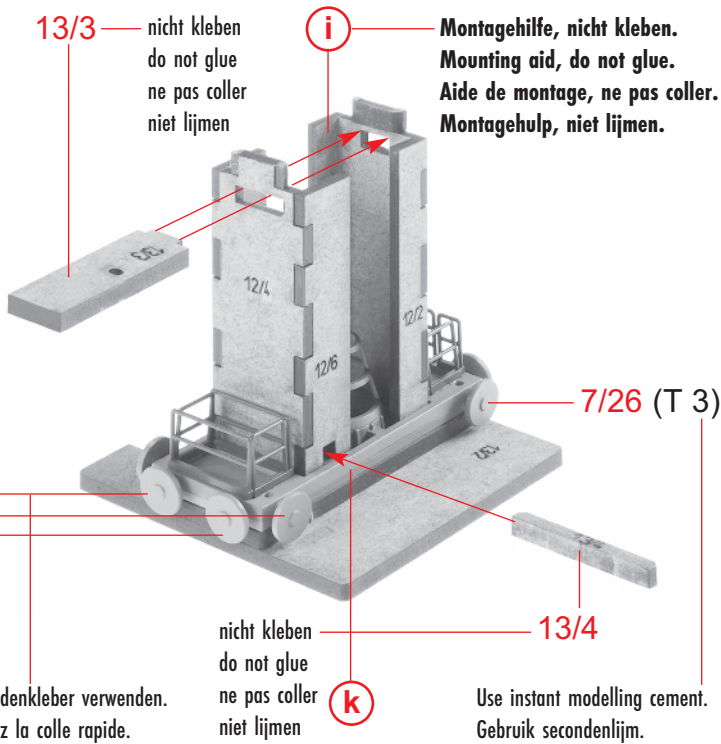

Inhalt Tüte 7
Contents bag 7
Contenu sachet 7
Inhoud zakje 7

Fadenverlauf 1.
Course of thread 1.
Trajet du fil 1.
Het verloop van de draden 1.

Faden spannen und mit Sekundenkleber fixieren!
Stretch the thread and fix with instant cement!
Étirer le fil et fixer avec de colle rapide !
Rek de garen uit en fixeren met secondenlijm!

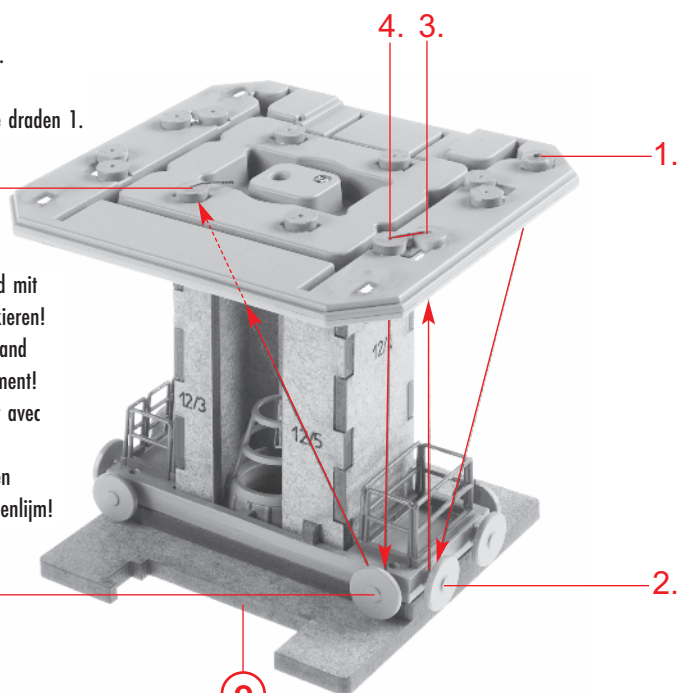

Fadenverlauf 2.
Course of thread 2.
Trajet du fil 2.
Het verloop van de draden 2.

Faden spannen und mit Sekundenkleber fixieren!
Stretch the thread and fix with instant cement!
Étirer le fil et fixer avec de colle rapide !
Rek de garen uit en fixeren met secondenlijm!

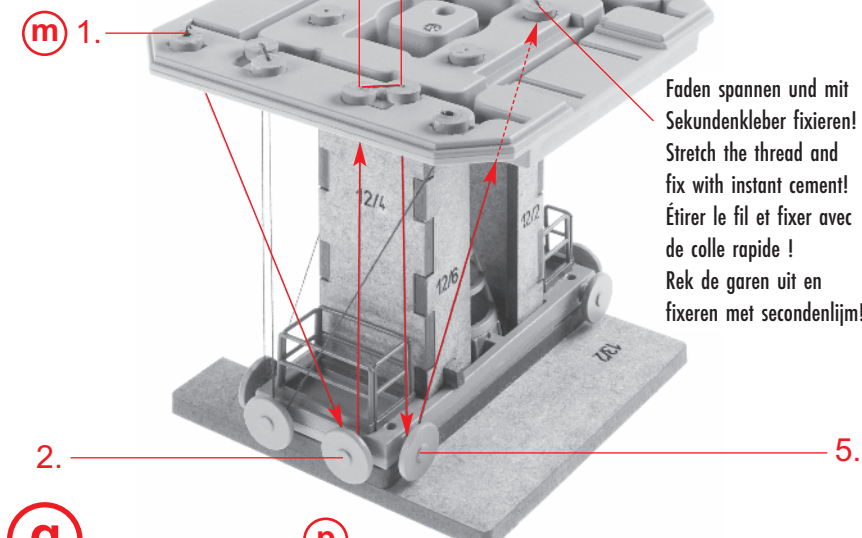

Fadenverlauf 3.
Course of thread 3.
Trajet du fil 3.
Het verloop van de draden 3.

Faden spannen und mit Sekundenkleber fixieren!
Stretch the thread and fix with instant cement!
Étirer le fil et fixer avec de colle rapide !
Rek de garen uit en fixeren met secondenlijm!

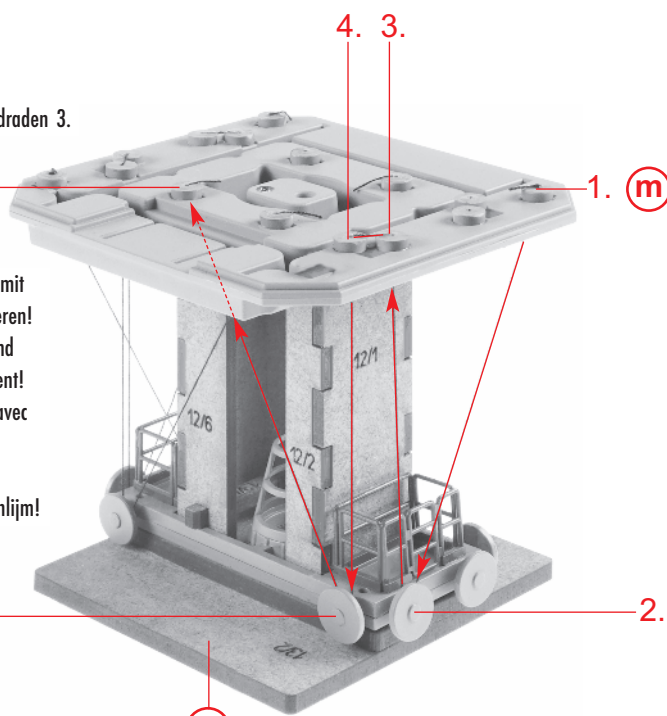

Fadenverlauf 4.
Course of thread 4.
Trajet du fil 4.
Het verloop van de draden 4.

Faden spannen und mit Sekundenkleber fixieren!
Stretch the thread and fix with instant cement!
Étirer le fil et fixer avec de colle rapide !
Rek de garen uit en fixeren met secondenlijm!

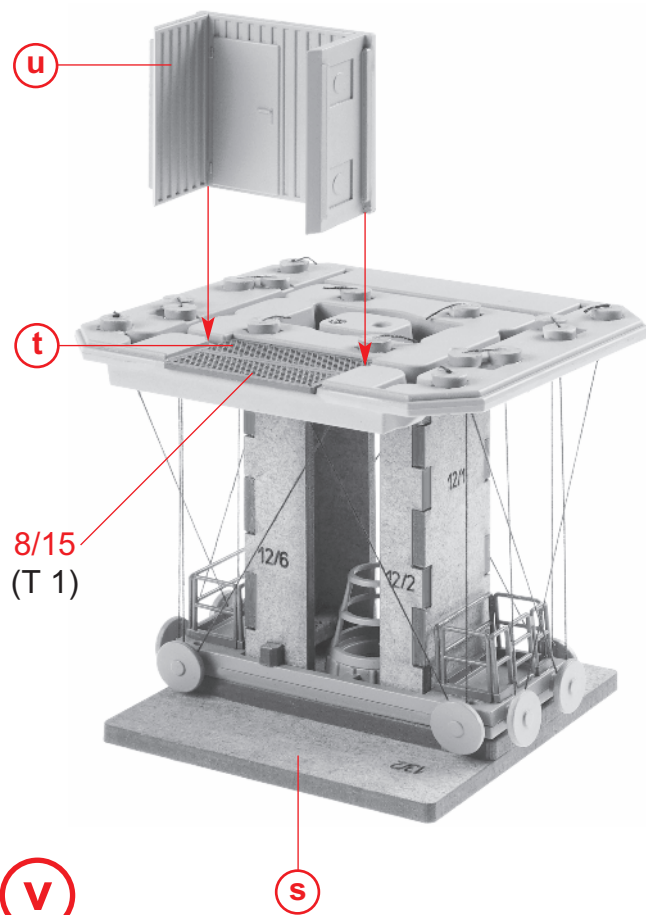
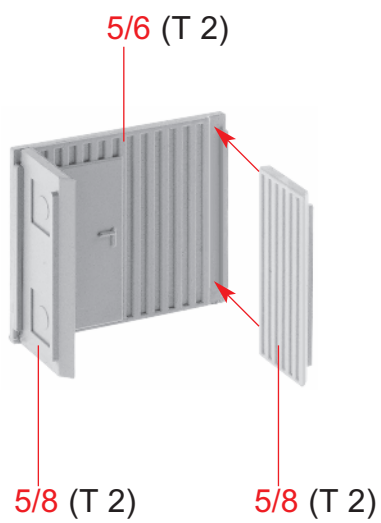
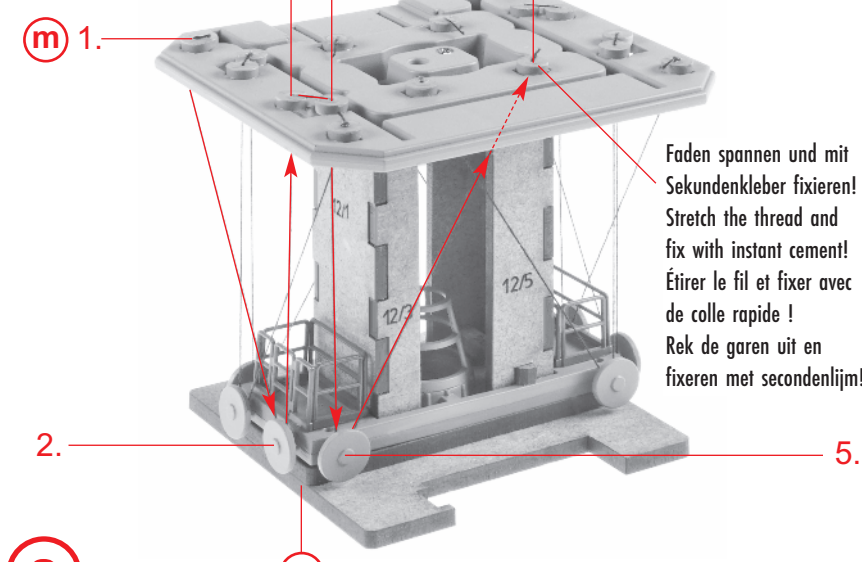

22

Inhalt	Tüte 1+2+4+5
Contents	bag 1+2+4+5
Contenu	sachet 1+2+4+5
Inhoud	zakje 1+2+4+5

5/11 (T 2) 5/10 (T 2)

5/10 (T 2) 5/7 (T 2) 5/10 (T 2)

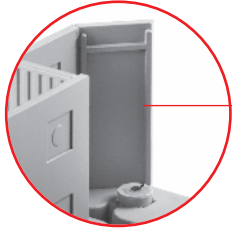

5/10 (T 2)

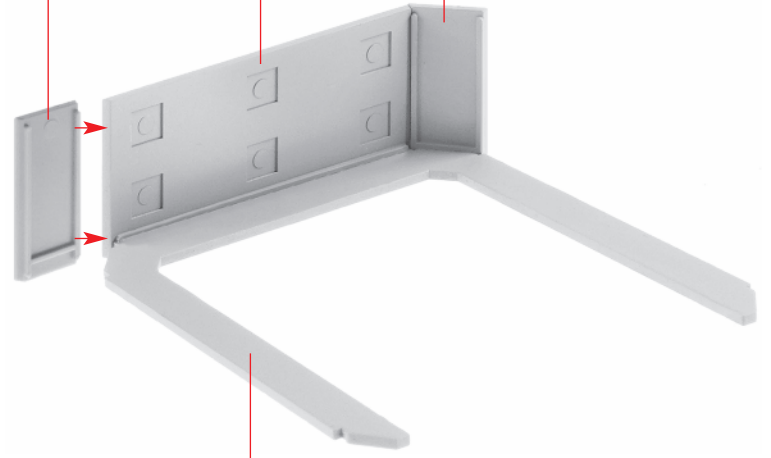
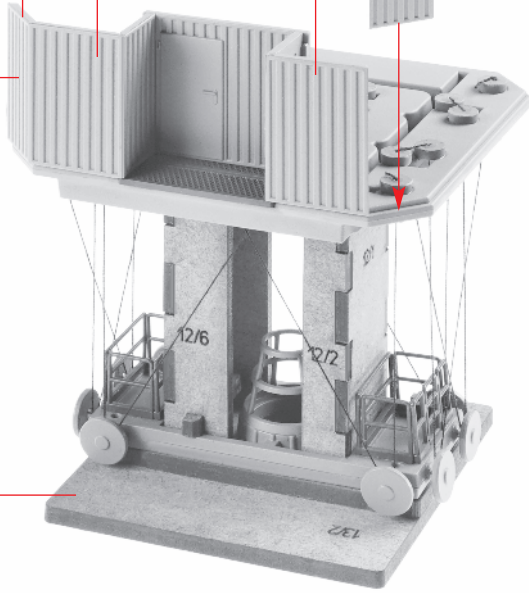

5/5 (T 2)

V
W

X

Schraube herausdrehen!
 Unscrew screw!
 Dévisser la vis !
 Draai de schroef los!

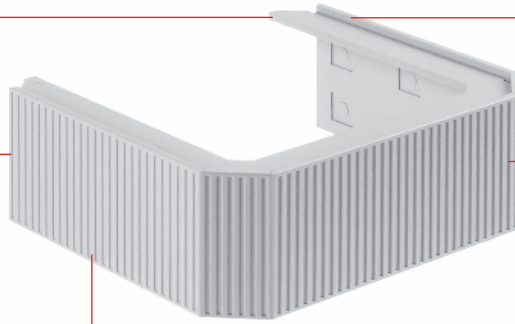
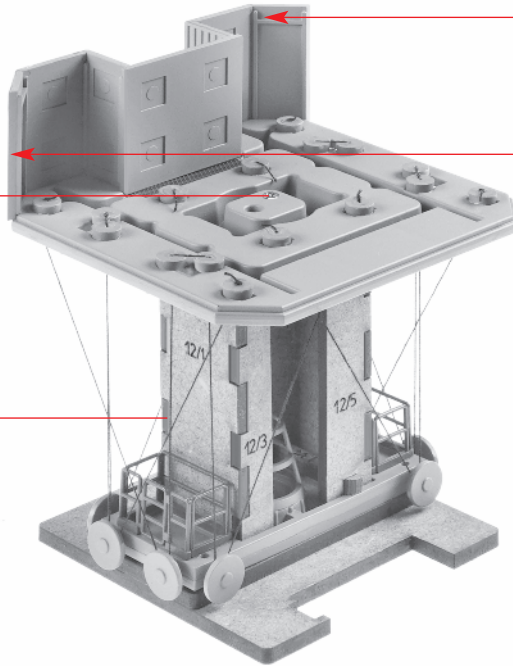

5/9 (T 2)

X

W

5/9 (T 2)

Y

9/21 (T 4)

f

9/21 (T 4)

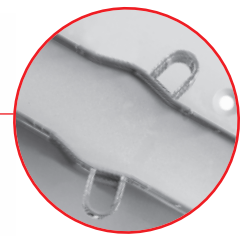
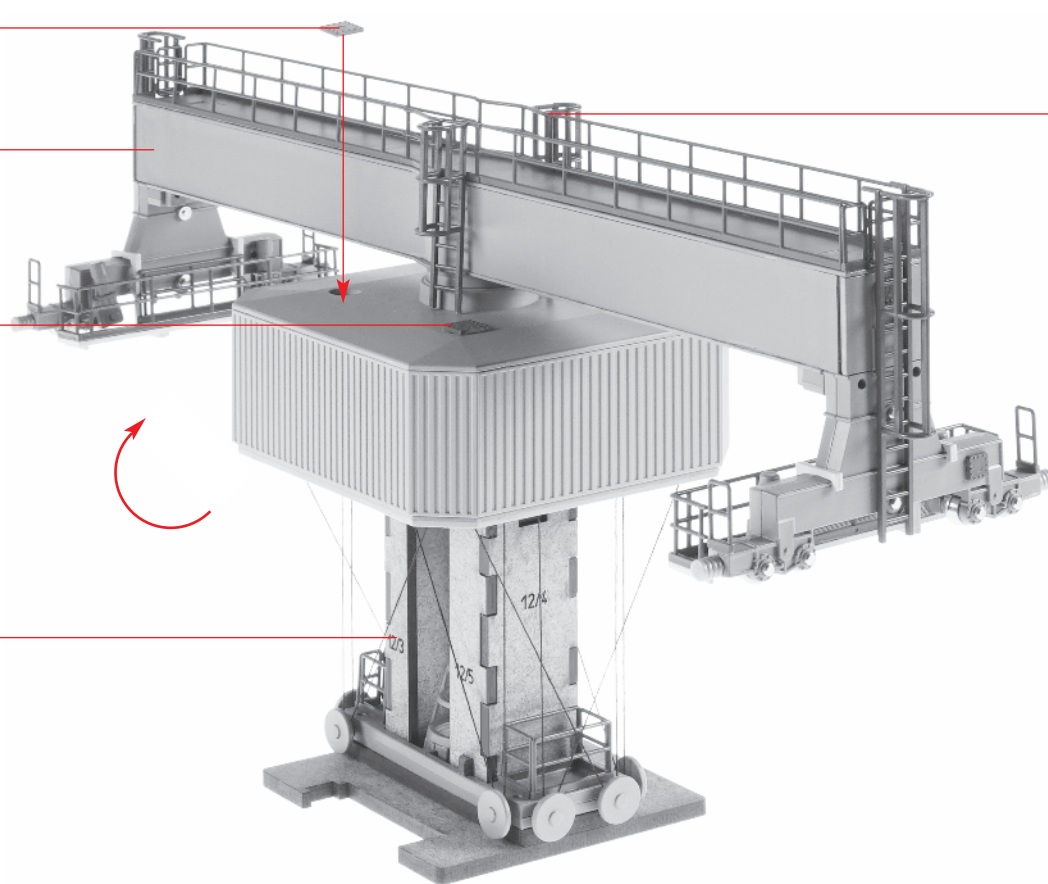

Y

Z

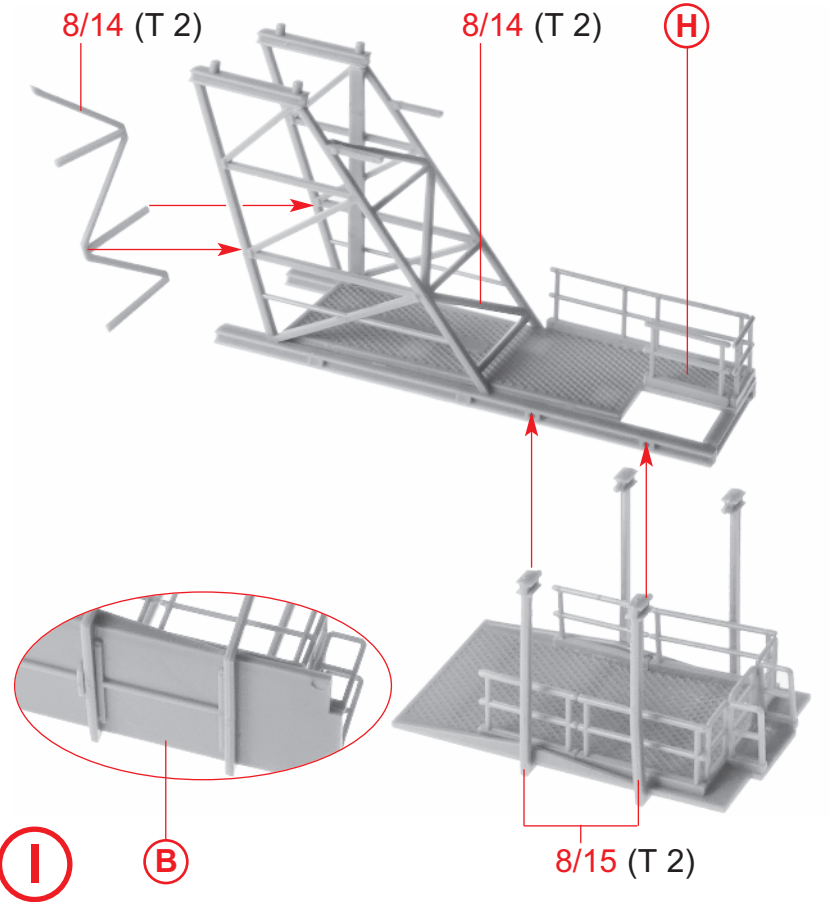
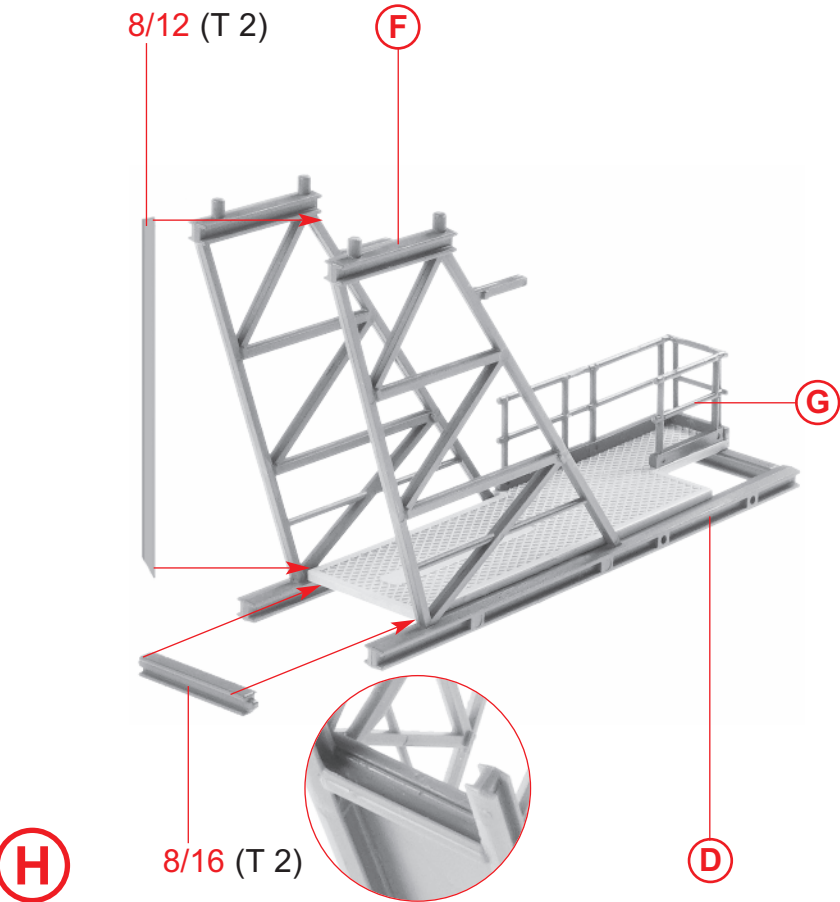
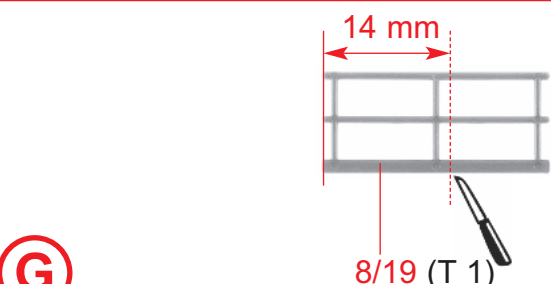
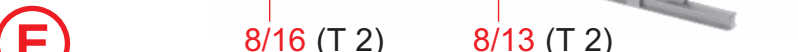
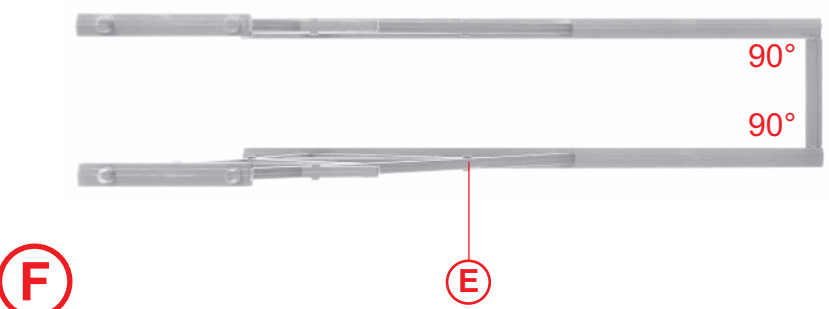
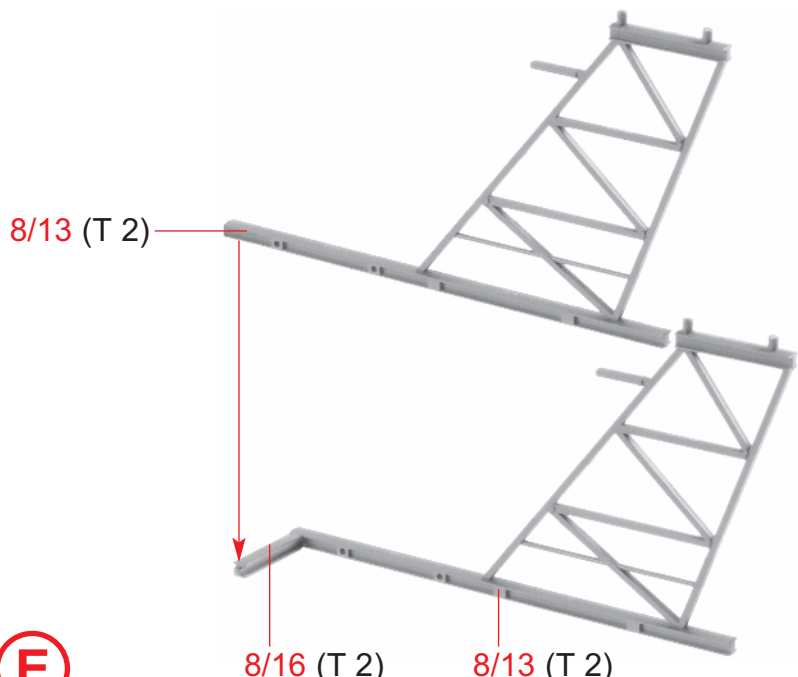
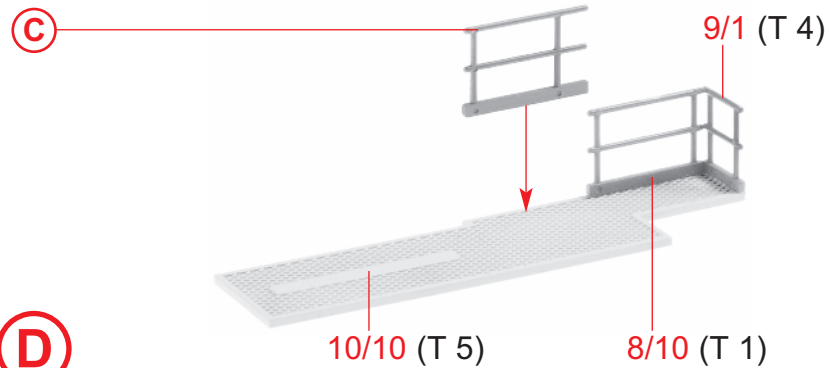
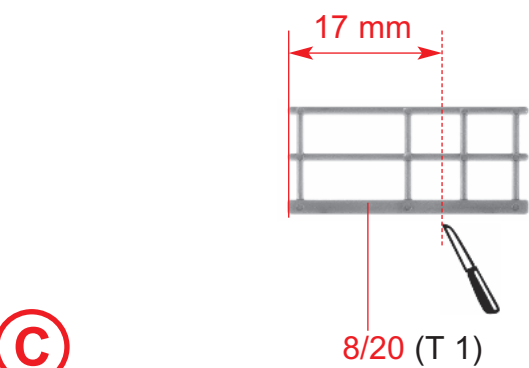
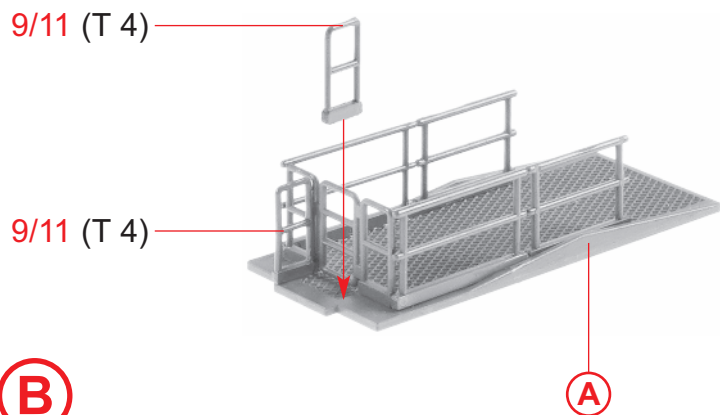
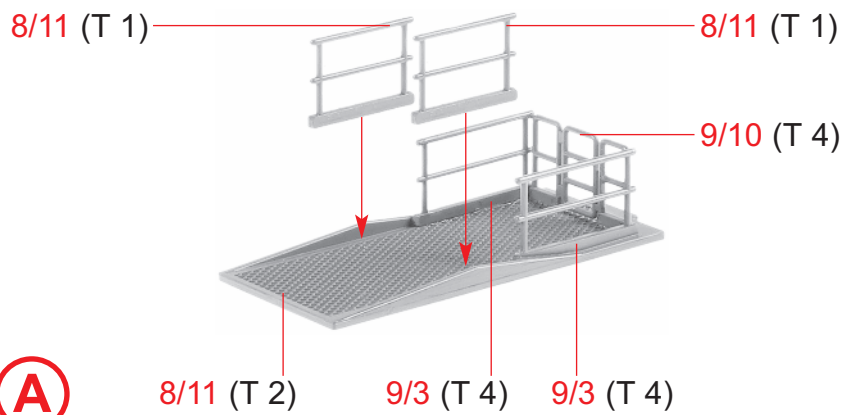

Inhalt	Tüte 1+2+3+4+5
Contents	bag 1+2+3+4+5
Contenu	sachet 1+2+3+4+5
Inhoud	zakje 1+2+3+4+5

Fensterfolie

Die beiliegende Fensterfolie entsprechend der benötigten Größe ausschneiden und vorsichtig mit wenig Klebstoff auf die Rückseite der Fensterrahmen aufkleben.

Window foil

Cut the attached window foil according the illustrations and glue it carefully with a little glue to the rear side of the window frames.

Feuillet transparent pour fenêtres

Découper le feuillet transparent pour fenêtres inclus d'après l'illustration. Coller proprement avec un peu de colle sur la face arrière du cadre des fenêtres.

Vensterfolie

De meegeleverde vensterfolie conform de afbeeldingen uitknippen of uitsnijden en voorzichtig met een beetje lijm op de achterzijde van het raam plakken.

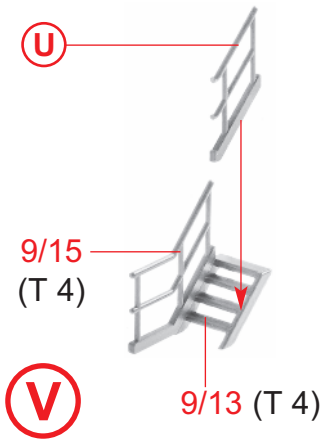
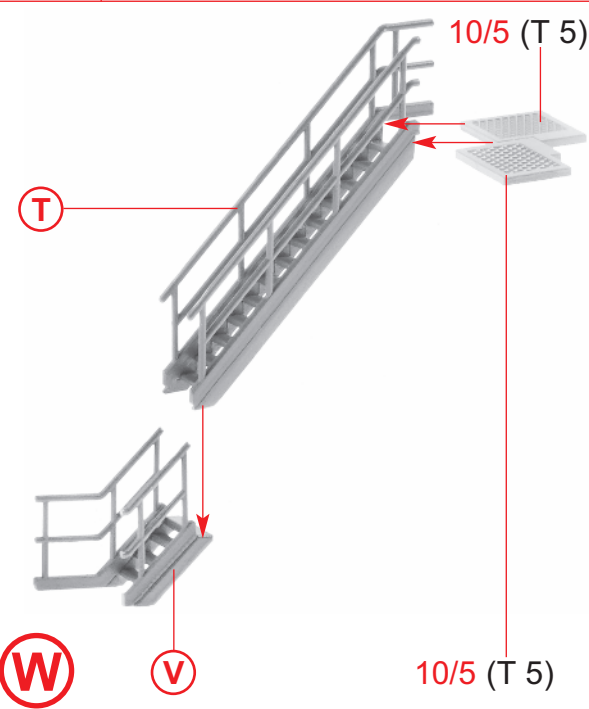
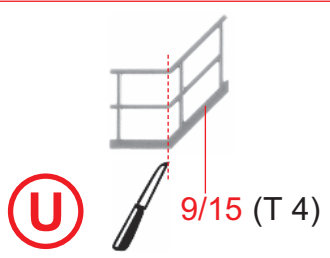
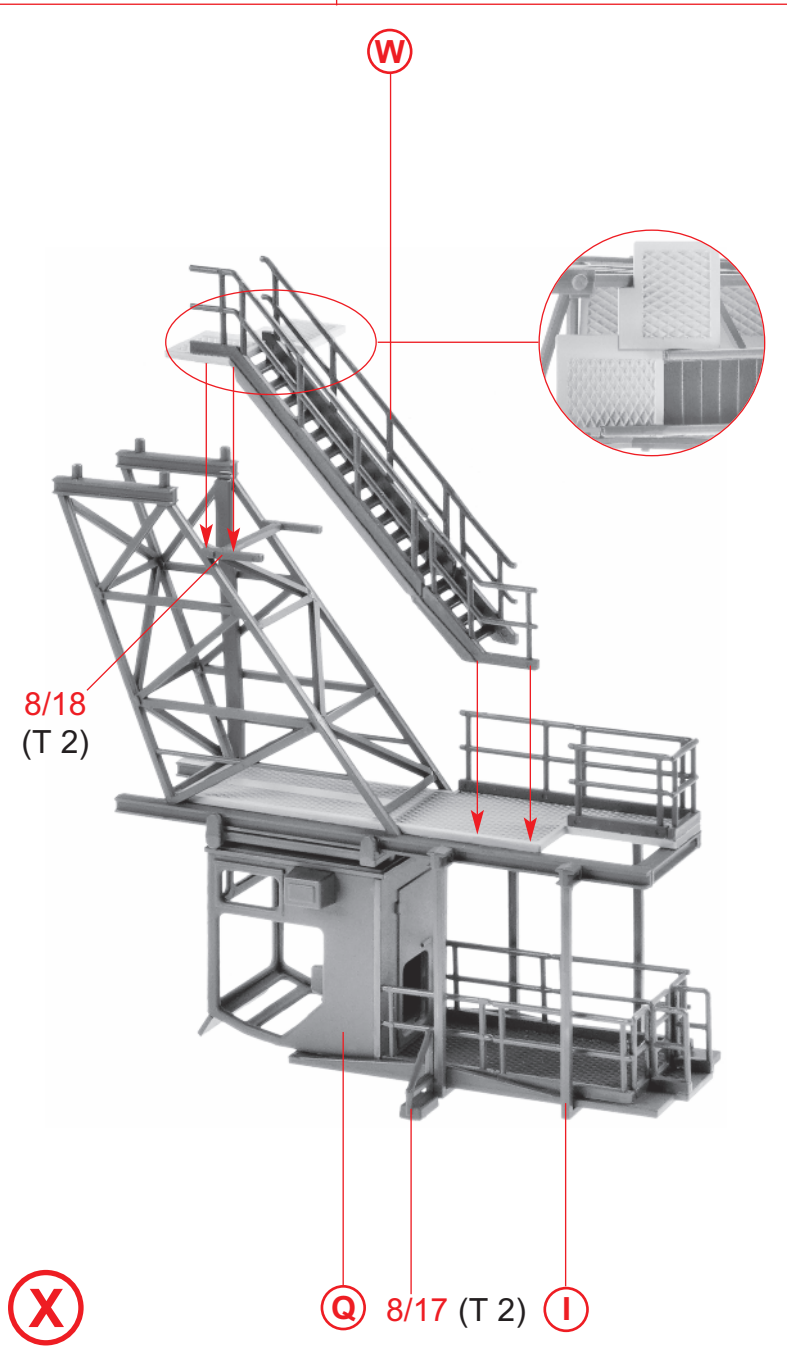
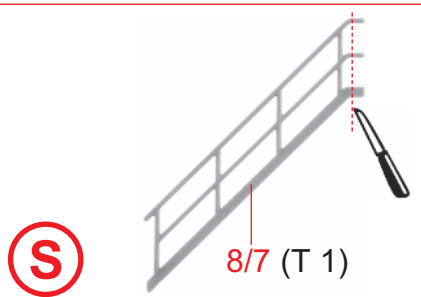
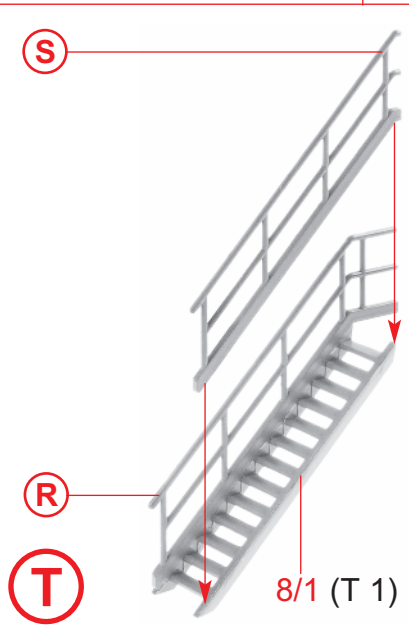
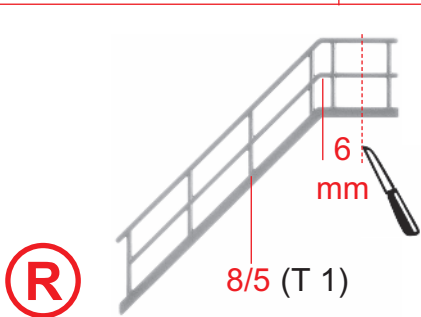
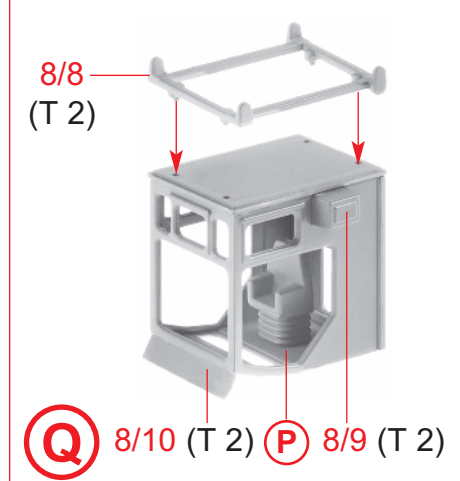
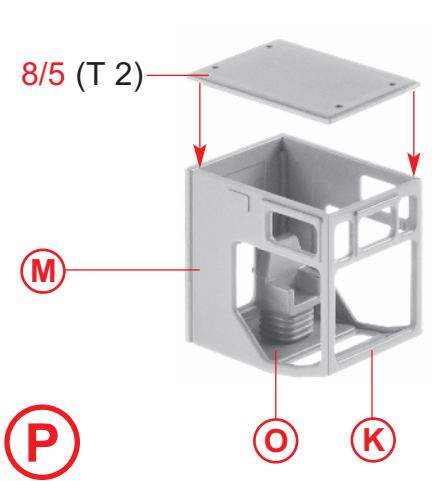
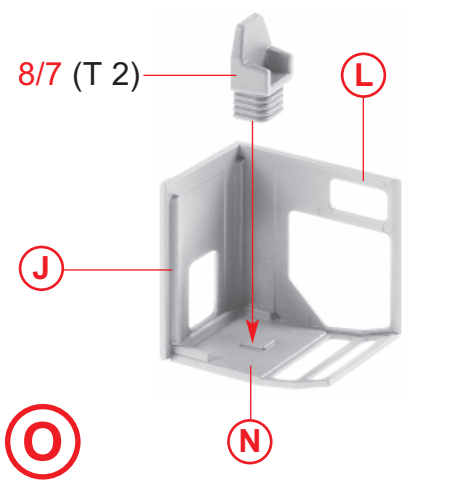
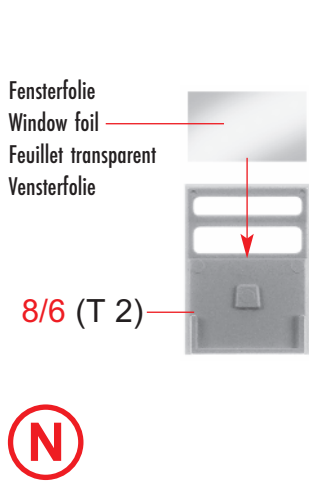
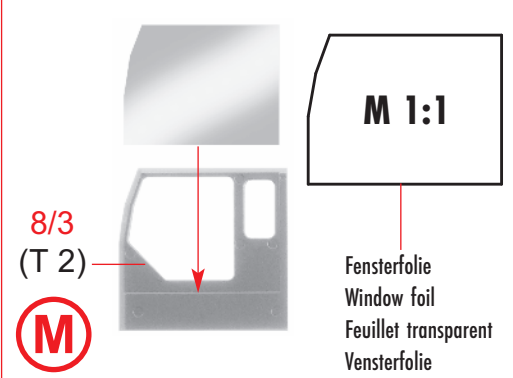
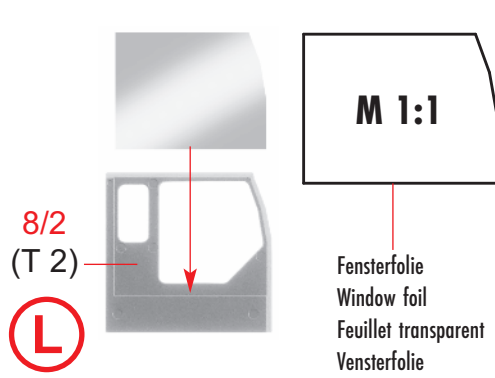
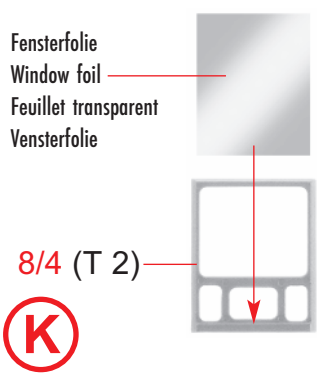
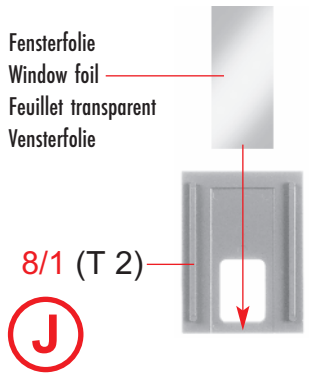

9/25 (T 4)

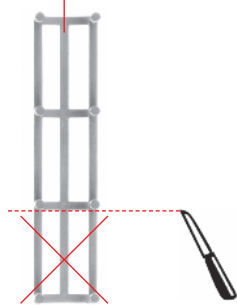

Y

8/17 (T 2)

X

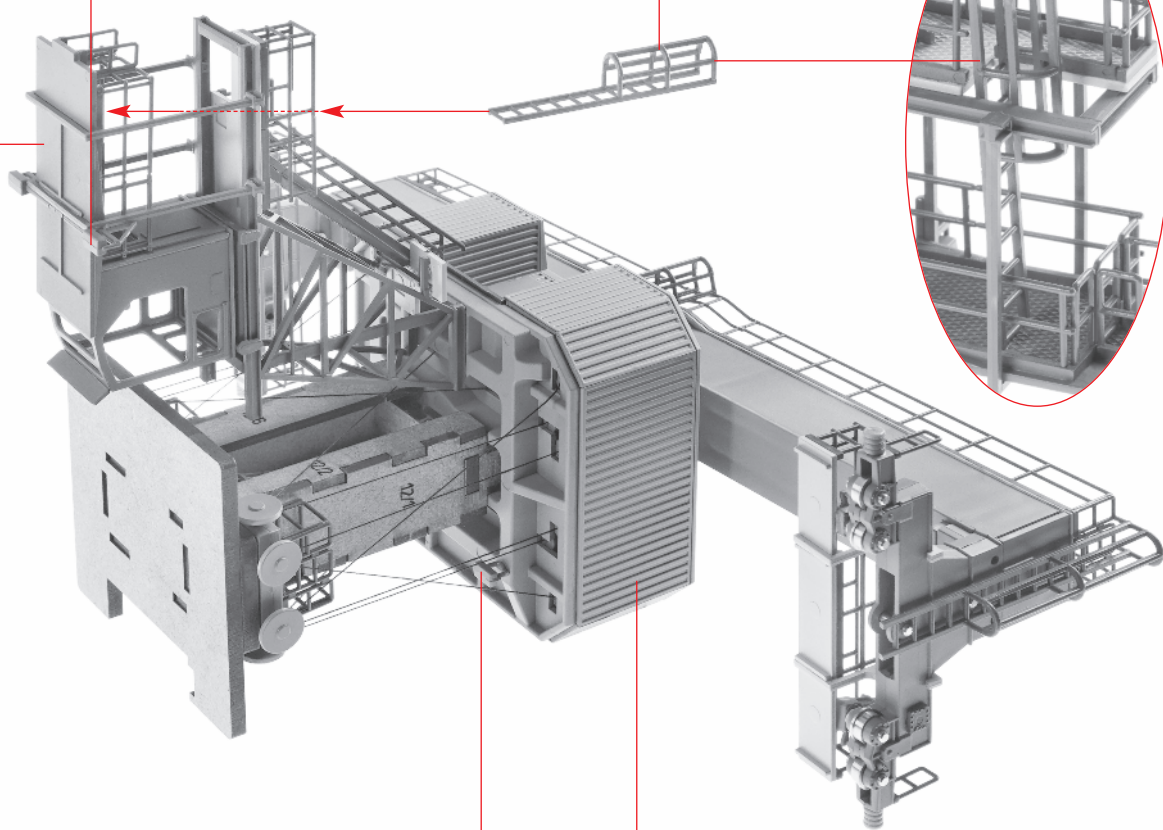

Z

Z

9/24 (T 4)

Y

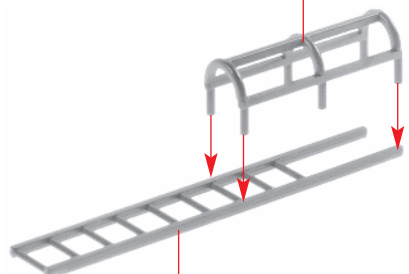

a

7/28 (T 3)

Z

1/6

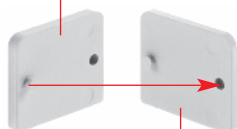

b

1/6

e

b

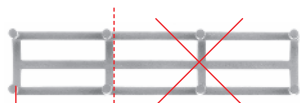
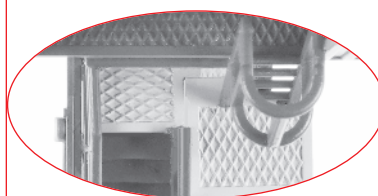

c

2 x 9/25 (T 4)

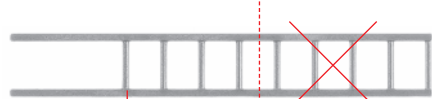

d

9/24 (T 4)



c

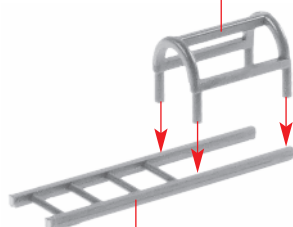

e

d

f

9/21 (T 4)

9/21 (T 4)

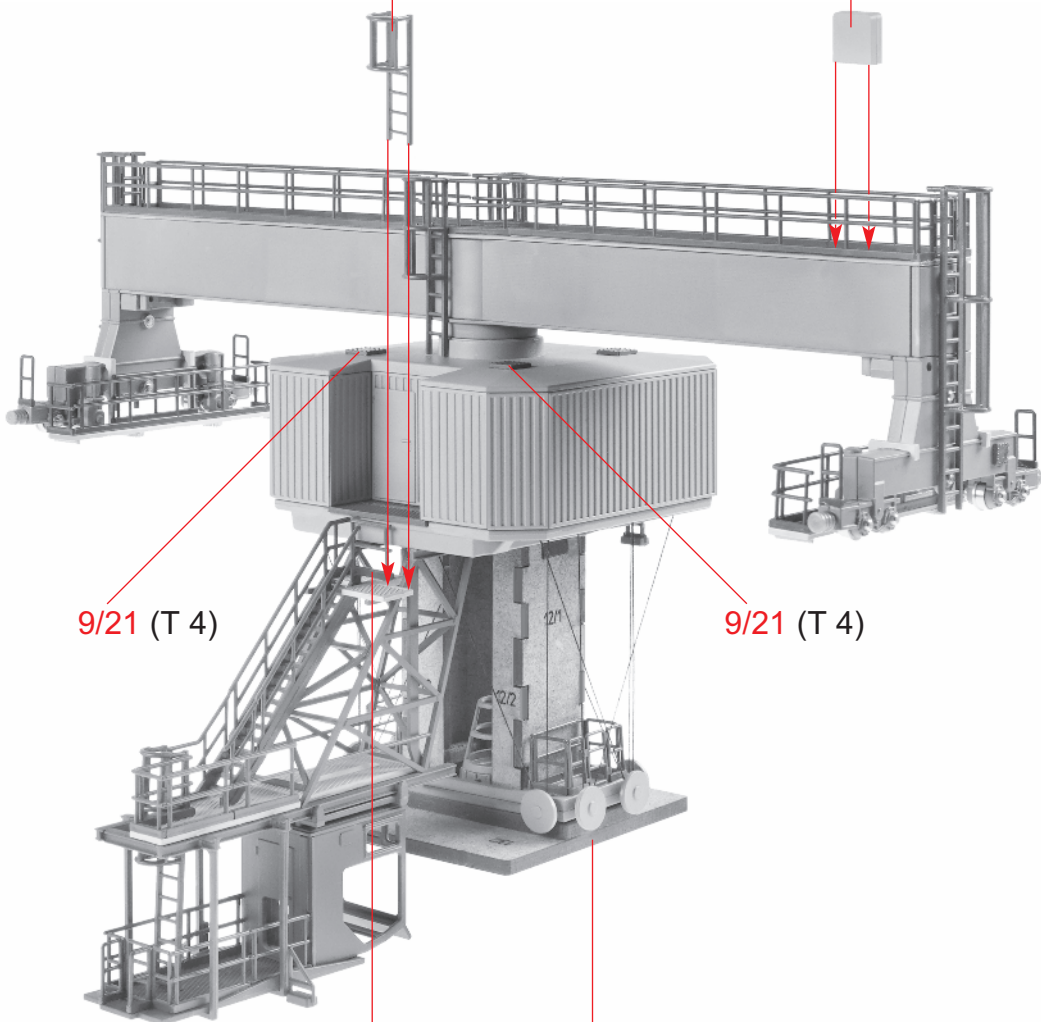

9/2 (T 4)

a

Inhalt	Tüte 1+3+4
Contents	bag 1+3+4
Contenu	sachet 1+3+4
Inhoud	zakje 1+3+4

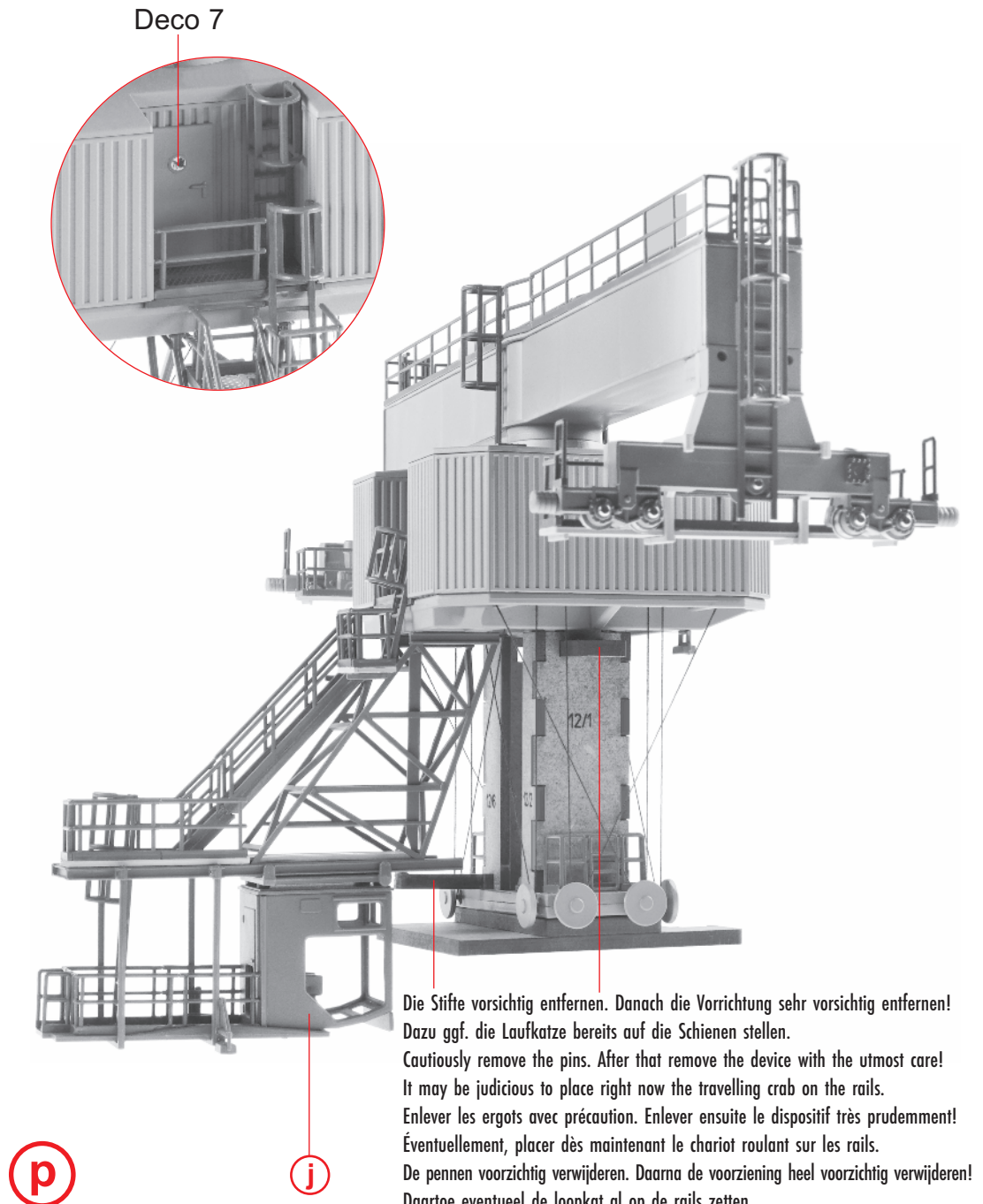
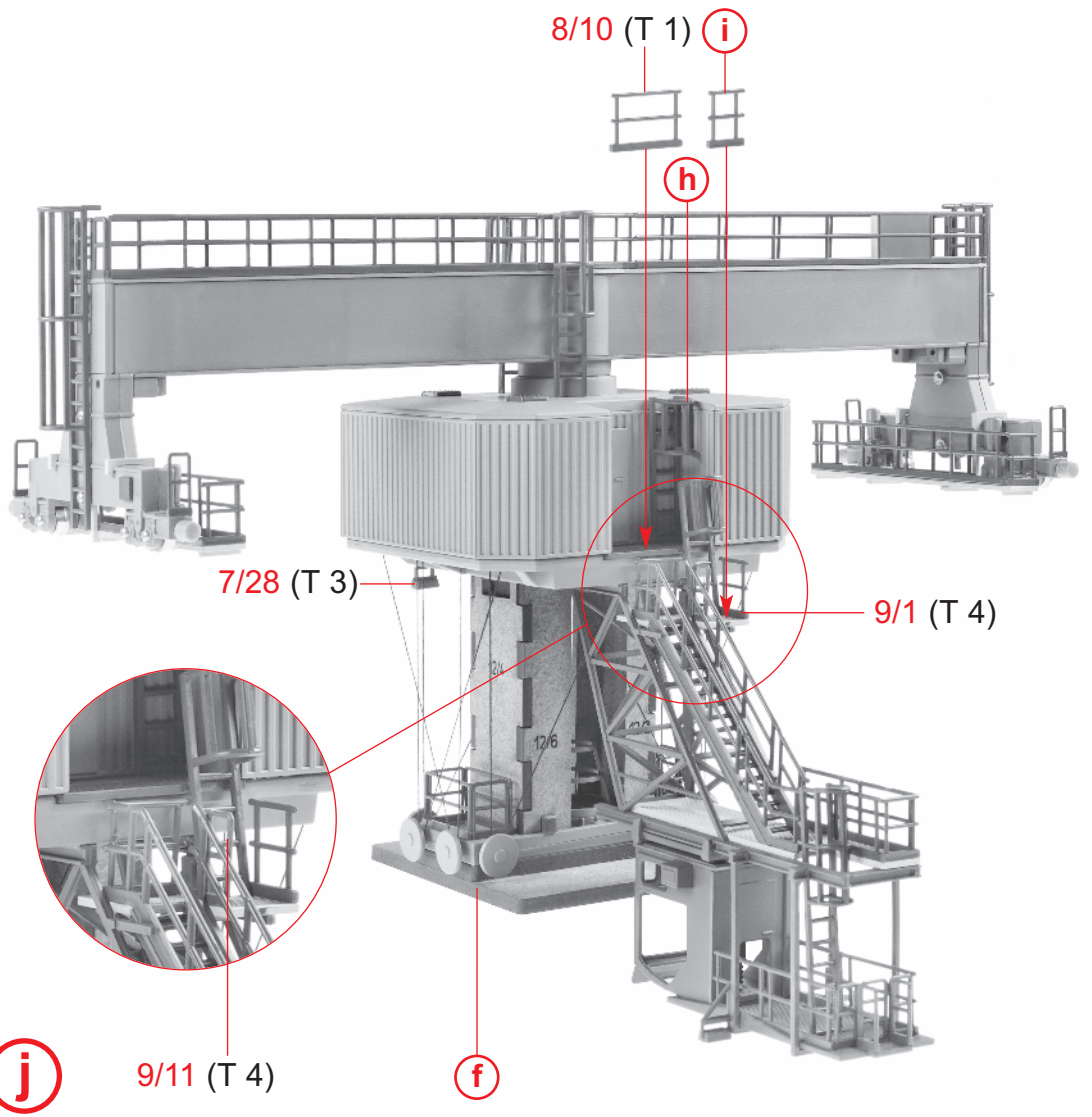
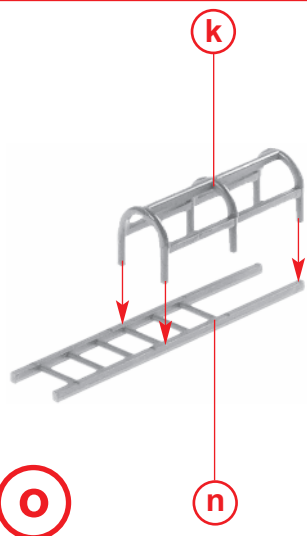
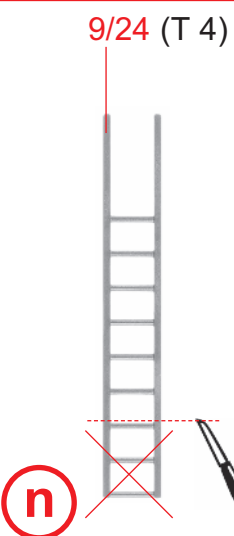
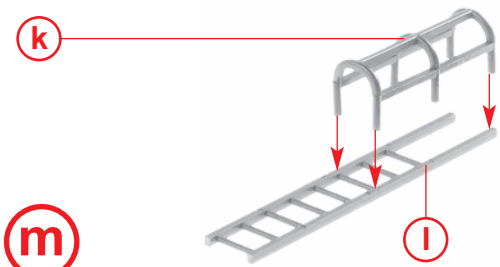
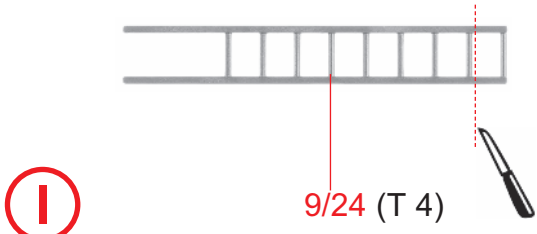
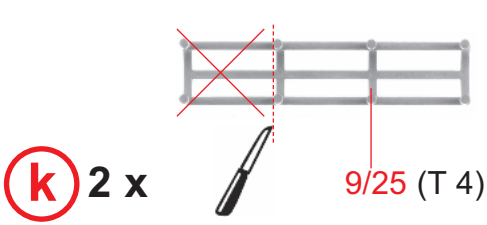
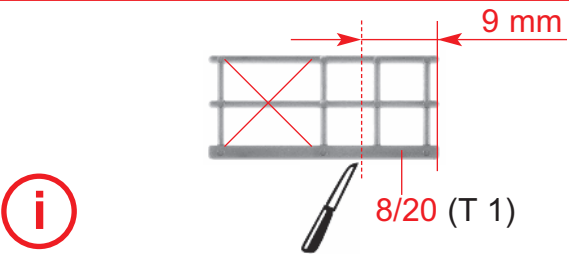
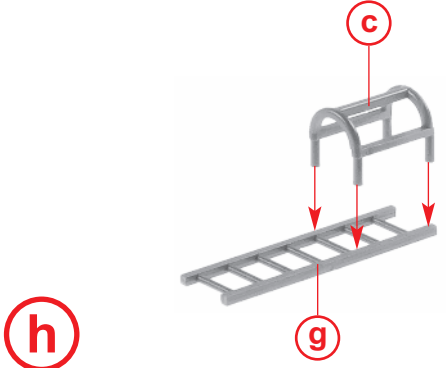
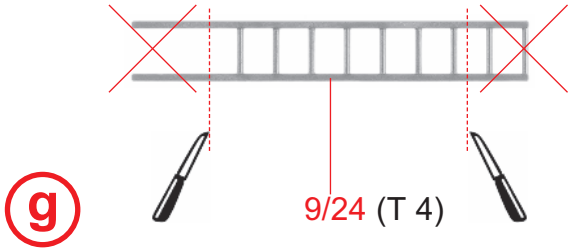

Die Stifte vorsichtig entfernen. Danach die Vorrichtung sehr vorsichtig entfernen!
 Dazu ggf. die Laufkatze bereits auf die Schienen stellen.
 Cautiously remove the pins. After that remove the device with the utmost care!
 It may be judicious to place right now the travelling crab on the rails.
 Enlever les ergots avec précaution. Enlever ensuite le dispositif très prudemment!
 Éventuellement, placer dès maintenant le chariot roulant sur les rails.
 De pennen voorzichtig verwijderen. Daarna de voorziening heel voorzichtig verwijderen!
 Daartoe eventueel de loopkat al op de rails zetten.

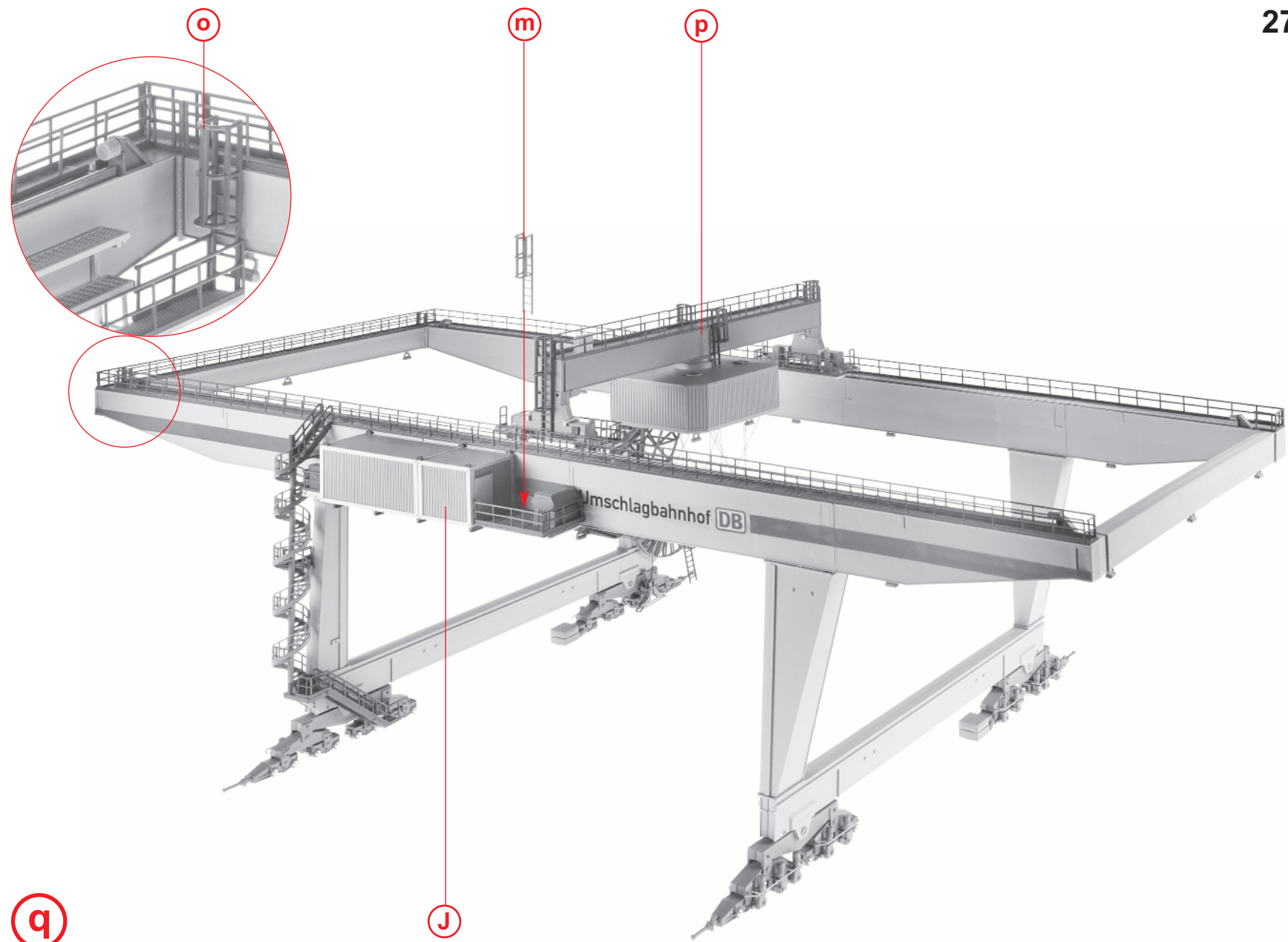

7/16 (T 3)

nicht kleben
do not glue
ne pas coller
niet lijmen

nicht kleben
do not glue
ne pas coller
niet lijmen

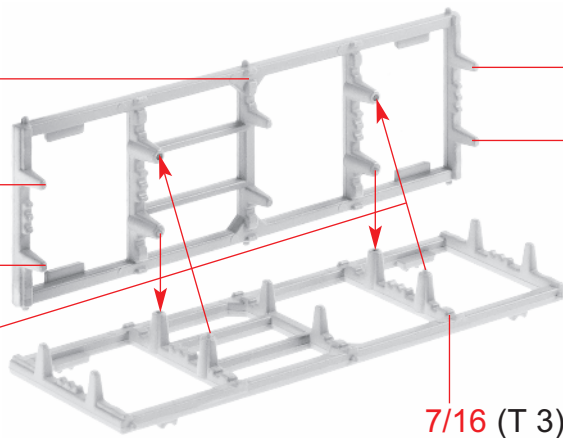

7/16 (T 3)

Nur an dieser Stelle kleben.
Only apply glue to this point.
Coller exclusivement cet emplacement.
Alleen op deze plaats lijmen.

r

7/24 (T 3)

nicht kleben
do not glue
ne pas coller
niet lijmen

7/24 (T 3)

nicht kleben
do not glue
ne pas coller
niet lijmen

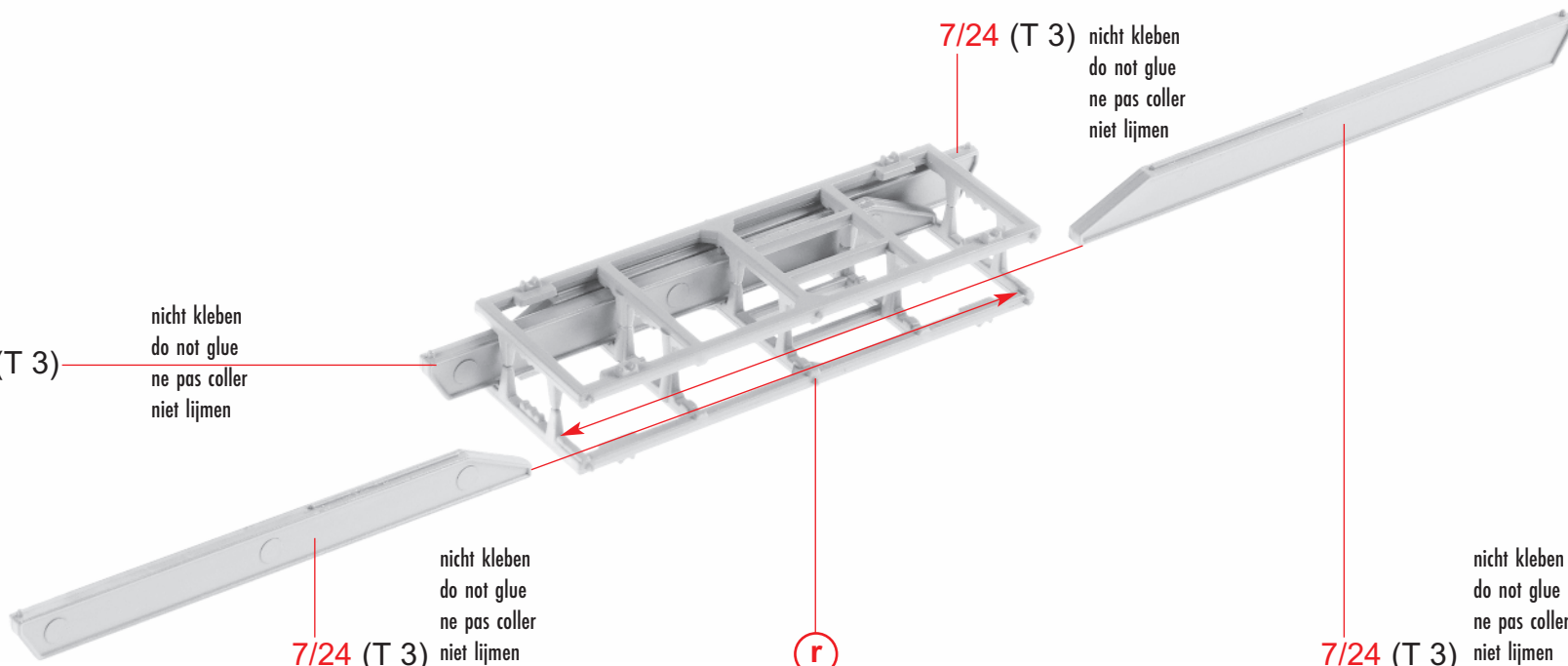

7/24 (T 3)

nicht kleben
do not glue
ne pas coller
niet lijmen

r

7/24 (T 3)

nicht kleben
do not glue
ne pas coller
niet lijmen

s

28

Inhalt	Tüte 3+6
Contents	bag 3+6
Contenu	sachet 3+6
Inhoud	zakje 3+6

7/23 (T 3)

S

7/23 (T 3)

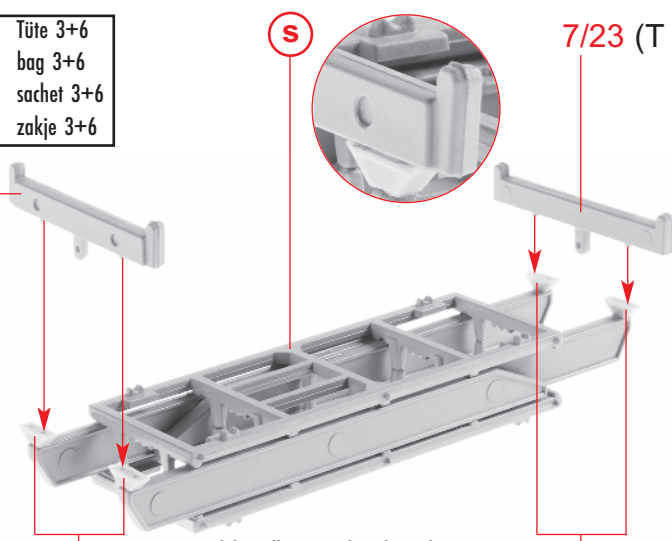

Klebestellen gut abtrocknen lassen!

Allow glue joints to dry well!

Laisser bien sécher les points de collage!

Alle gelijmde punten goed laten drogen!

t

7/25 (T 3)

7/25 (T 3)

u

7/21 (T 3)

Nur an dieser Stelle kleben.
Only apply glue to this point.
Coller exclusivement cet emplacement.
Alleen op deze plaats lijmen.

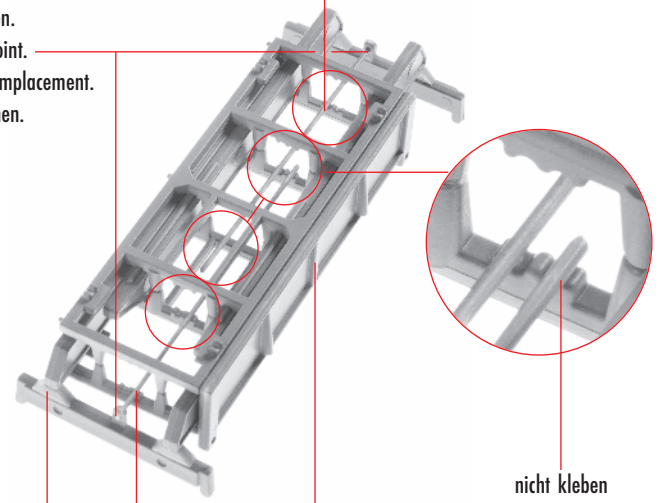

nicht kleben
do not glue
ne pas coller
niet lijmen

t

7/21 (T 3)

7/17 (T 3)

7/20 (T 3)

7/20 (T 3)

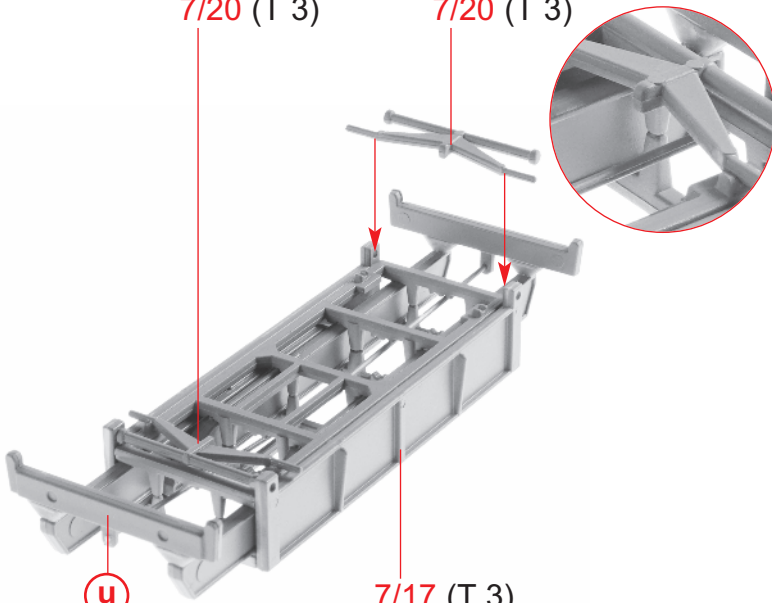

v

u

7/17 (T 3)

w

2 x

Deco 11

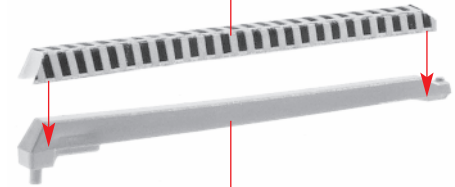

4/23 (T 6)

Deco 12

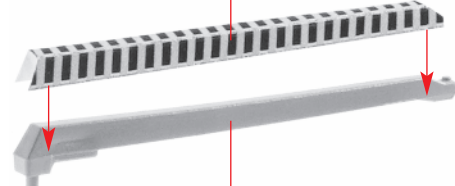

4/23 (T 6)

x

2 x

7/18 (T 3)

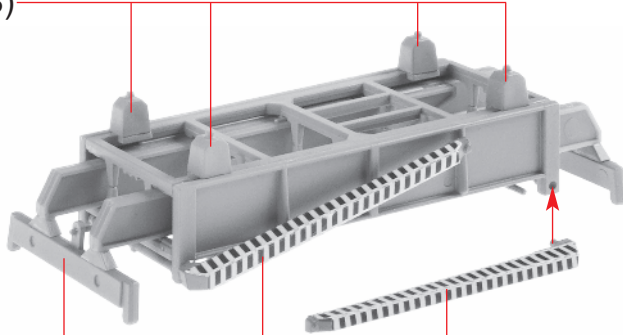

y

v

w

x

7/22 (T 3)

Deco 8

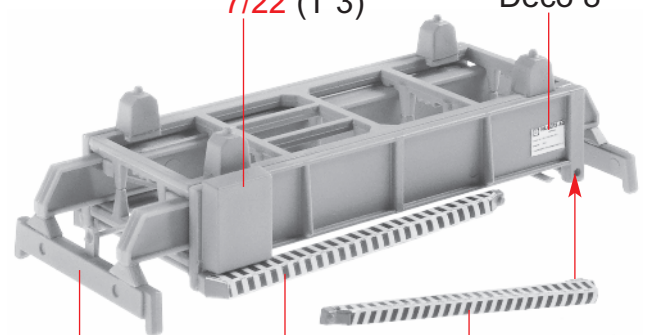

z

y

w

x

20' Container
20' Container
20' Conteneur
20' Container

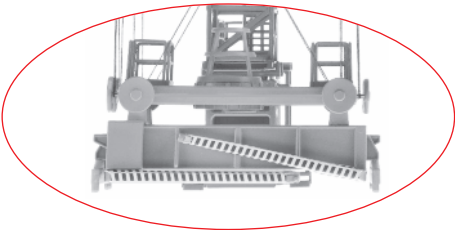

40' Container
40' Container
40' Conteneur
40' Container

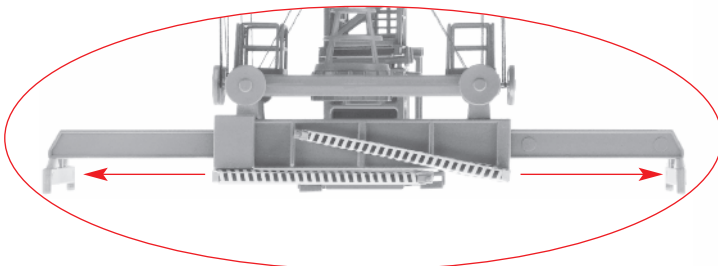

A

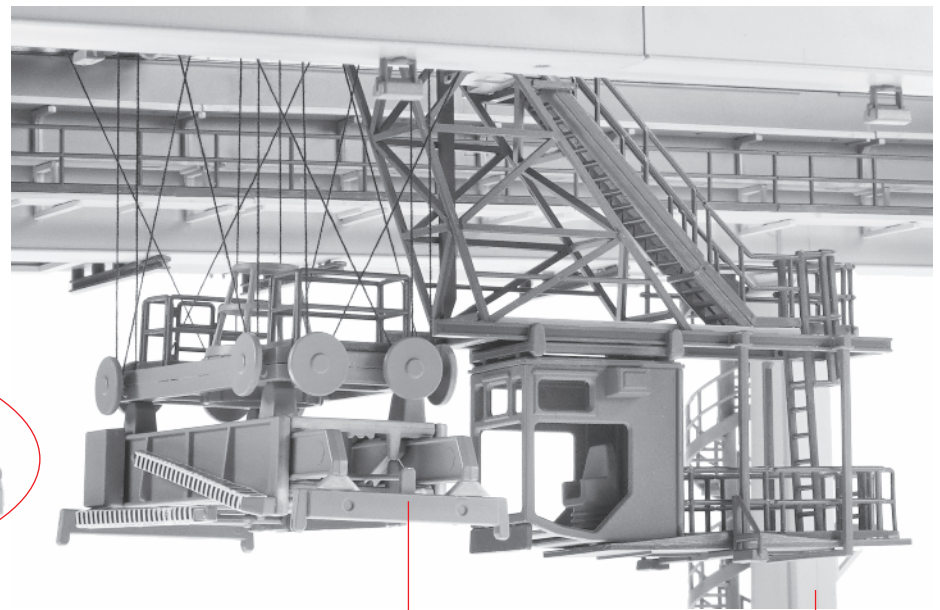

z

q

Deco 2

Deco 9

Deco 10

Deco 1

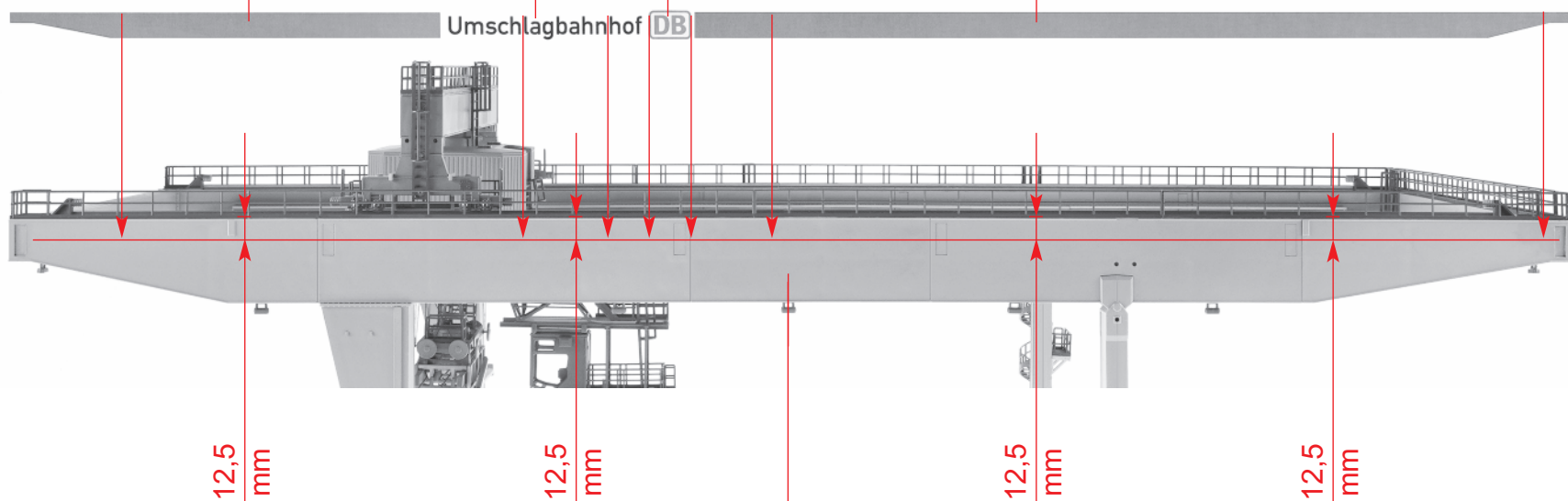

B

A

Deco 6

Deco 5

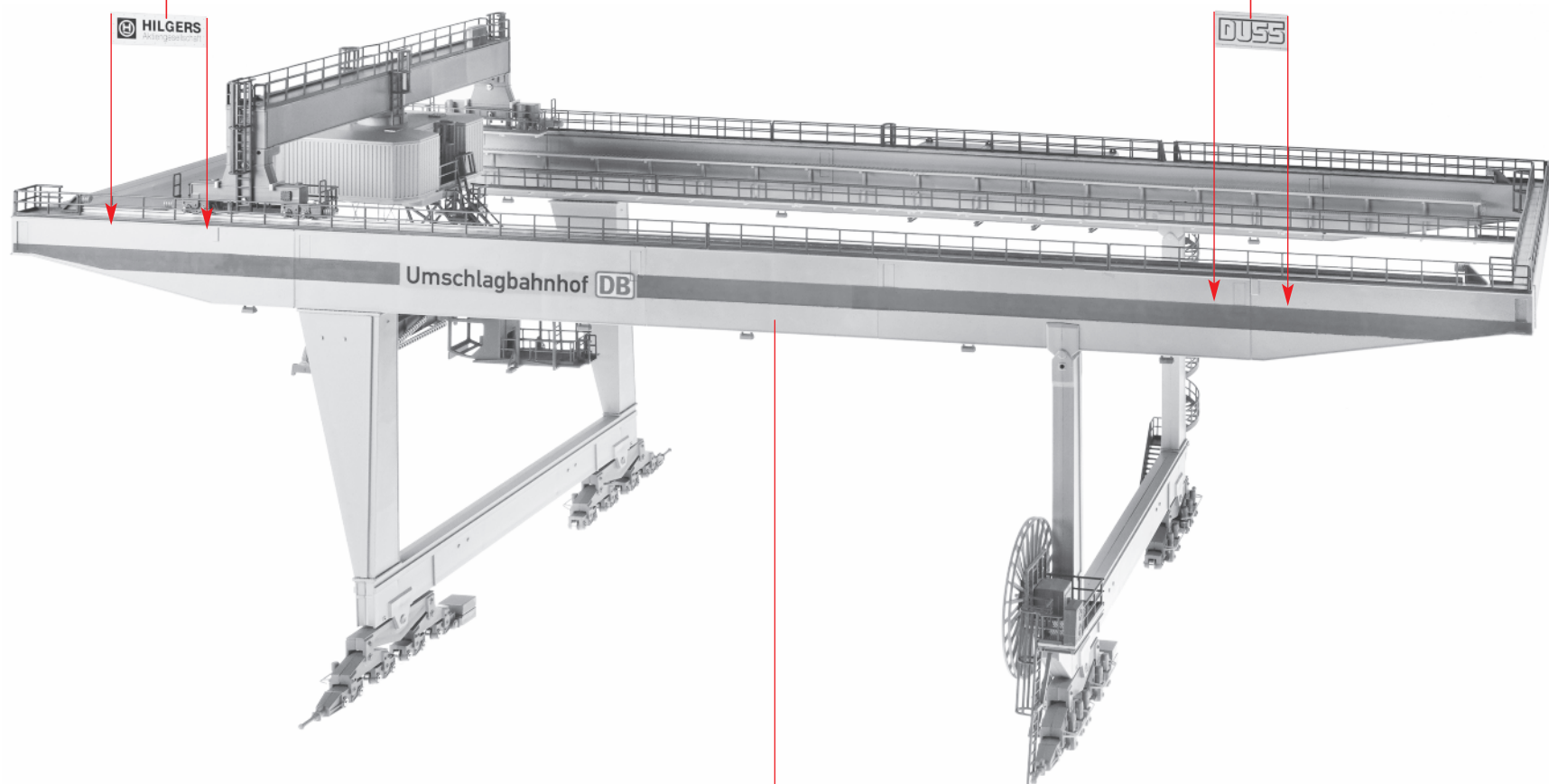

C

B

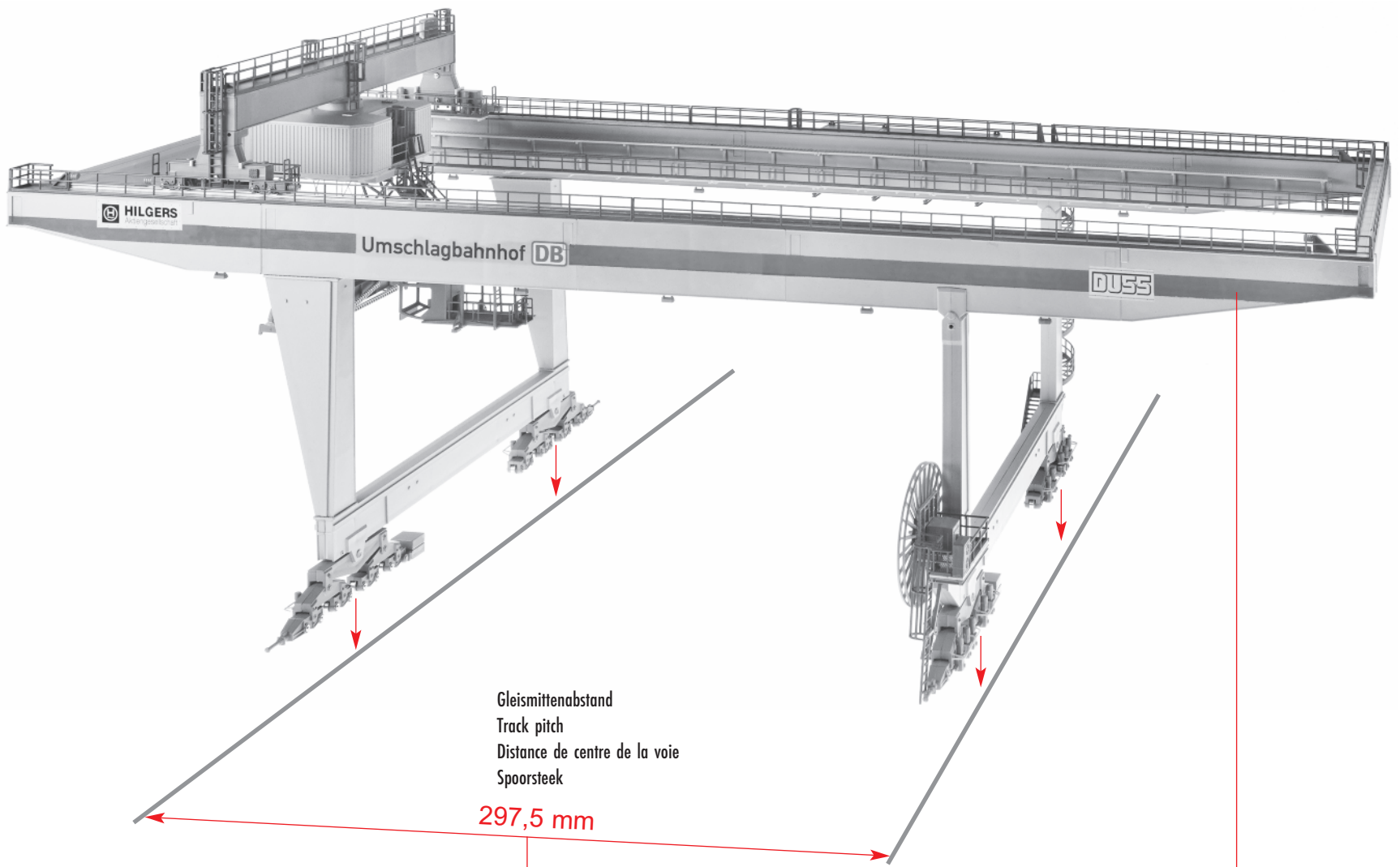

Inhalt	Tüte 8	Contents	bag 8
Contenu	sachet 8	Inhoud	zakje 8
Schienen		Tracks	
Voies		Rails	

Achtung: Die Containerbrücke ist in verschiedenen Längen baubar. Die Geländer müssen dann entsprechend gekürzt werden.
Caution: The Container bridge-crane can be built with different lengths. Railings must then be shortened accordingly.
Attention: On peut construire le Portique à conteneurs en différentes longueurs. Il faut alors raccourcir les garde-corps de façon correspondante.
Let op: de containerkraan kan in verschillende lengtes worden gebouwd. De balustrades moeten dan passend worden ingekort.

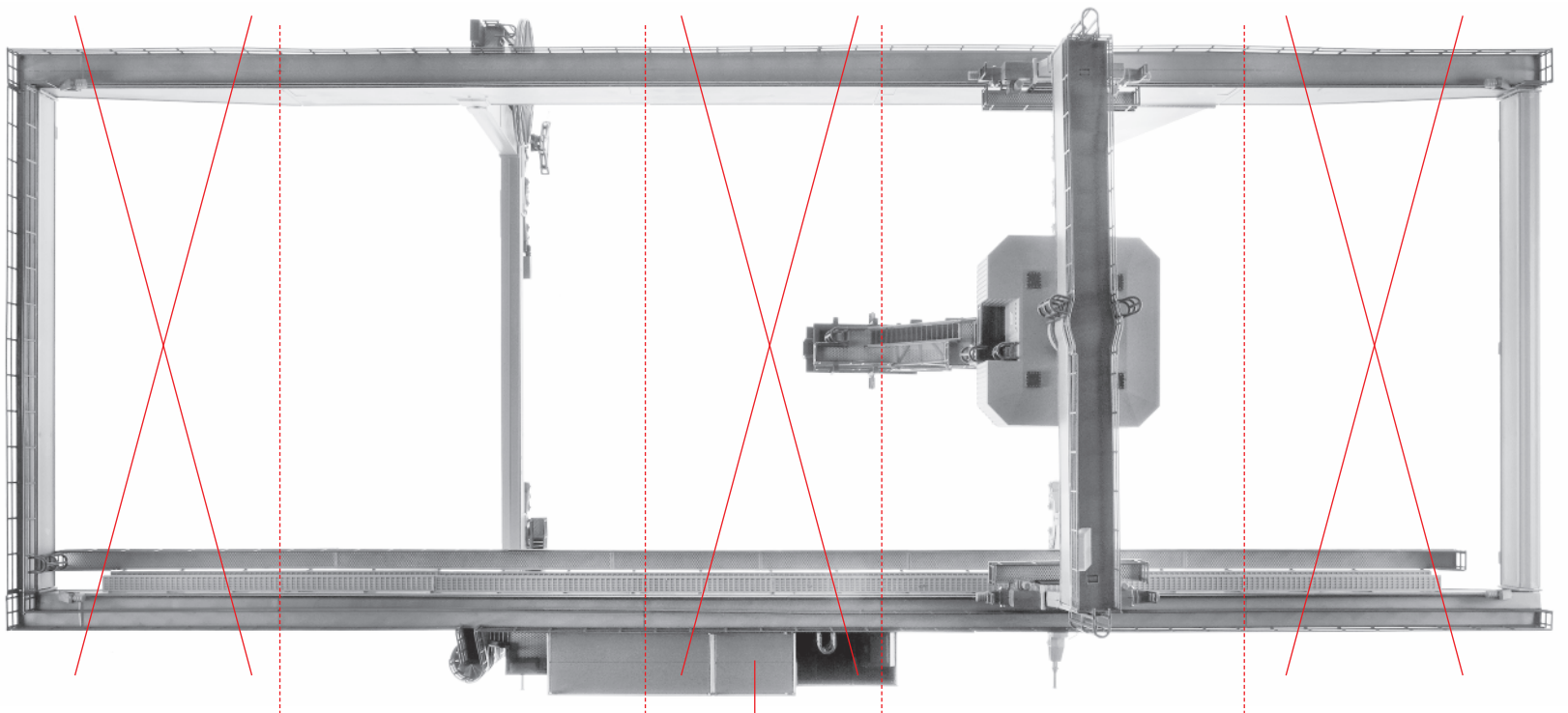

Deco 6

Deco 5

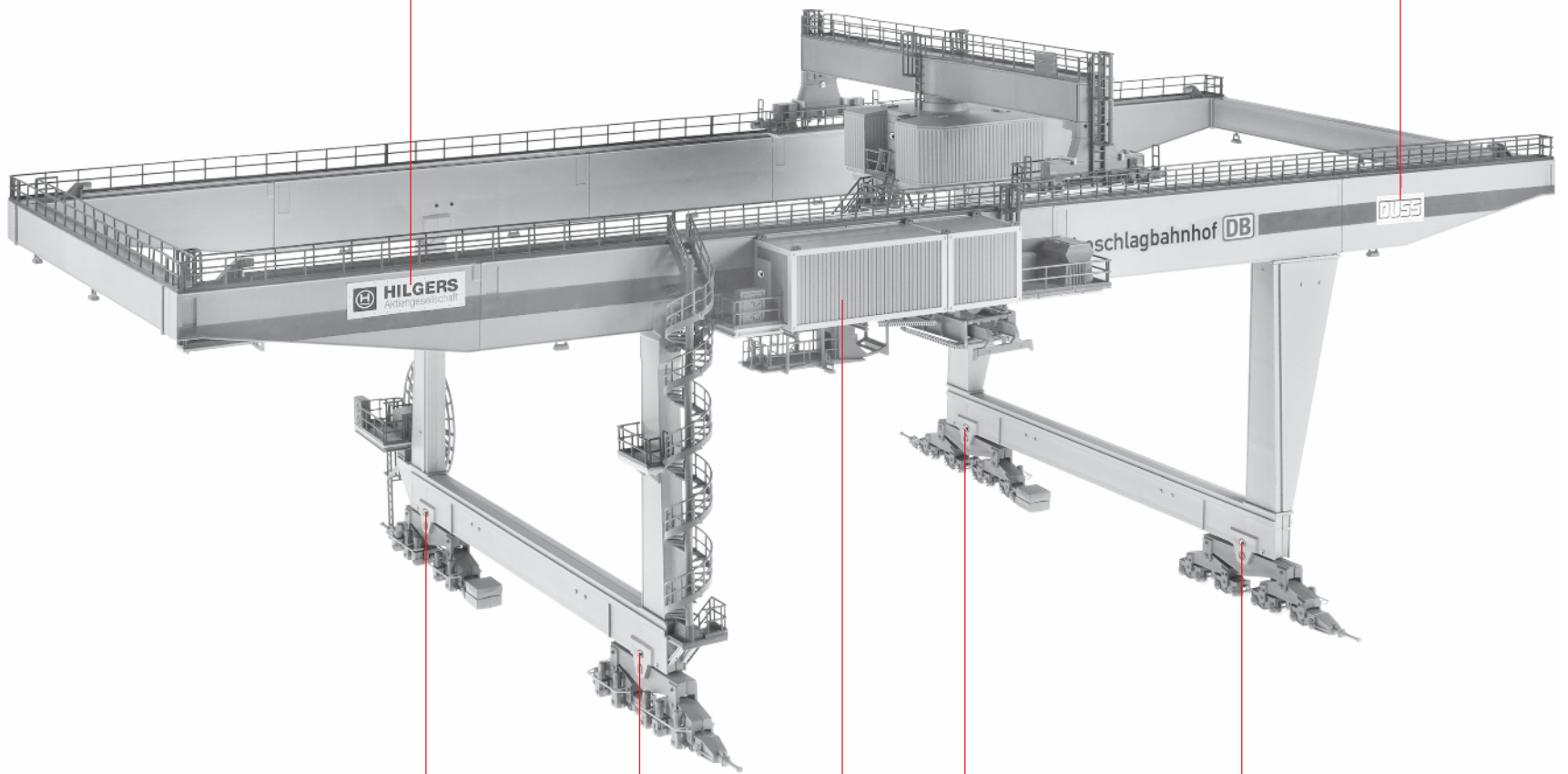

Deco 7

Deco 7

E

Deco 7

Deco 7